

## **SAFETY OF SALT CAVERNS USED FOR UNDERGROUND STORAGE**

### ***SEGURANÇA NAS CAVERNAS SALINAS UTILIZADAS NO ARMAZENAMENTO SUBTERRÂNEO***

BÉREST, PIERRE \*  
BROUARD, BENOÎT \*\*

#### **ABSTRACT**

This paper focuses on the safety of deep underground salt caverns used to store hydrocarbons. By “deep”, we mean caverns with depths ranging between 500 m and 2000 m. These caverns are leached out from salt formations, and there are thousands of such caverns that have been implemented throughout the world. Underground storage is the safest way to store large quantities of hydrocarbons. This statement may seem paradoxical as a topic of a paper concerning risks, hazards and accident reports. In fact, however, judging the safety of any type of facility must be based on an estimate of the shortcomings of alternative systems. Underground storage facilities are much safer in terms of safety and environmental protection than steel and concrete tank farms at the ground surface.

#### **RESUMO**

A segurança de cavernas salinas, utilizadas para a armazenagem subterrânea de hidrocarbonetos, é analisada para o caso das cavernas profundas. Estas cavernas caracterizam-se por se situarem entre 500 e 2000 m de profundidade. São cavernas que foram lixiviadas em formações de sal gema, existindo milhares destas cavernas em todo o mundo. A armazenagem subterrânea é o processo mais seguro de armazenar grandes quantidades de hidrocarbonetos. Esta afirmação poderá parecer paradoxal para o tema de um estudo sobre os riscos, falhas e acidentes relacionados com esta solução técnica. De facto, a segurança de qualquer instalação deve ser baseada numa estimativa das limitações de sistemas alternativos. As instalações de armazenagem subterrânea são muito mais seguras em termos de protecção ambiental e segurança global do que as instalações tradicionais de betão e aço à superfície.

(\* ) *G.3S and LMS, Ecole Polytechnique, France*

(\*\* ) *LMS and Brouard Consulting, France*

## 1. INTRODUCTION: SOLUTION-MINED CAVERNS

This paper focuses on the safety of deep underground salt caverns used to store hydrocarbons. By “deep”, we mean caverns with depths ranging between 500 m and 2000 m. These caverns have been leached out from salt formations: a (typically) 1-km deep well is cased and cemented to the rock formation, and the casing-shoe is anchored to the upper part of the salt formation. A central string is set inside the well, like a straw in a bottle, allowing soft water to be injected at the bottom of the cavern. Water leaches the salt wall, and brine is removed from the cavern through the annular space between the cemented casing and the central injection tube. After 1 year or more, a 10,000-m<sup>3</sup> to 1,000,000-m<sup>3</sup> cavern will be created (Fig. 1). In many cases, the cavern is later used for hydrocarbon storage (crude oil, LPG or natural gas): some brine is removed from the cavern, and hydrocarbons are substituted for the removed brine. Generally, one to several strings are set in the well to allow injection or withdrawal of fluids into or from the cavern.

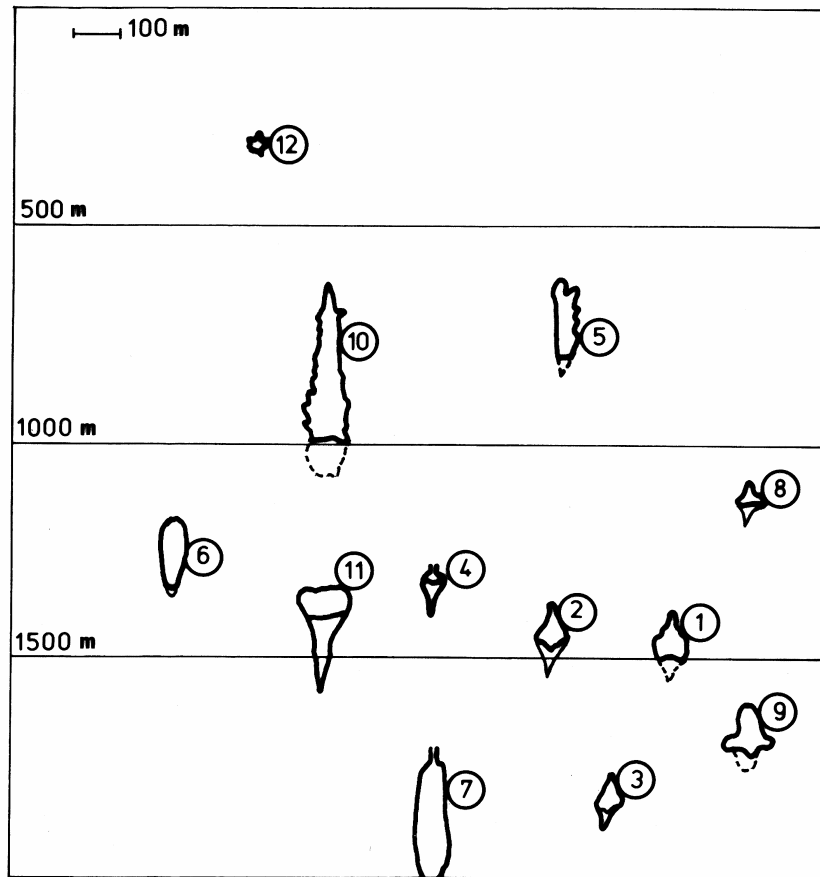

Figure 1 - Solution-mined caverns. 1. Tersanne 2. Etrez 3. Atwick 4. Kiel 5. Huntorf 6. Epe 7. Eminence 8. Melville 9. Regina 10. Manosque 11. Hauterives 12. Carresse.

Thousands of such caverns have been implemented throughout the world (Thoms and Gehle, 2000) [1]. An abundant literature is available on all aspects of solution-mining techniques, including safety. The Solution Mining Research Institute (SMRI), which gathers companies, consultants and research centers involved in the solution-mining industry, has published hundreds of technical papers dedicated to solution-mined caverns.

### ? **Storage-Cavern Safety**

Underground storage is the safest way to store large quantities of hydrocarbons. This statement may seem paradoxical as a topic of a paper concerning risks, hazards and accident reports. In fact, however, judging the safety of any type of facility must be based on an estimate of the shortcomings of alternative systems. Hydrocarbons can be stored in underground storage facilities, or in steel and concrete tank farms at the ground surface. Underground storage facilities are much safer in terms of safety and environmental protection: underground, hydrocarbons are separated from the oxygen in the air (necessary for combustion) by several hundred meters of rock; this same natural barrier protects them from fire, willful damage and aircraft impact; high storage pressures present no problem insofar as high pressure is the natural state of the fluids underground; and, last but not least, underground storage is extremely economical in terms of land area.

However, hydrocarbons are valuable because they release large quantities of energy when they burn or explode. This makes them hazardous to transport or store. Poorly designed or operated underground storage facilities can lead to severe accidents. Much has been learned from hundreds of caverns operated for decades; case histories of such accidents provide the best lessons for preventing further problems.

## **2. FLUID EQUILIBRIUM IN A DEEP CAVERN (BLOW OUT)**

### **2.1 Introduction**

A storage cavern is a pressure vessel: high pressure fluids are contained in a stiff impervious envelope, and a system of valves allows the cavity to be sealed off. However, caverns differ from standard pressure vessels in two respects:

1. The “container” consists of the access well and the cavern proper (typically, the height of such a system is 1 km). The well is equipped with several tubes containing various fluids (brine and hydrocarbons). Even a small difference in fluid density results in very different column weights. At the same depth, the gap between fluid pressures can be several MPa large. This generates unstable situations when the various fluids come into direct contact accidentally.
2. The volume of a cavern body is very large (up to 1,000,000 m<sup>3</sup>). Even a small pressure drop results in a significant change in the volume of the stored product. Liquid compressibility, an often negligible notion in most above-ground vessels, plays a significant role when large underground cavern are considered.

How these two factors generate specific difficulties is described below.

## 2.2 Pressure Distribution in a Salt Cavern — Consequences of Well Failure

### 2.2.1 Liquid and liquefied products

Storage facilities for liquids (oil, naphtha, kerosene, gasoline) and liquefied hydrocarbons (LPG, ethylene, propylene) are operated by the “brine compensation” method. As brine is injected through a central tube (see Fig. 2) at the bottom of the cavern, an equivalent volume of products is withdrawn through the annular space between the steel cemented casing and the central tube. When the cavern is idle, the brine is at atmospheric pressure at ground level.

In the brine tube, however, the pressure is in proportion to the depth and specific density of brine, which is of the order of  $1200 \text{ kg}\cdot\text{m}^{-3}$ . If the interface between the oil and brine is 1000 m below ground level, the pressure at this point will be approximately 12 MPa. At the interface, brine pressure and product pressure are equal. Above this point, the pressure in the product-filled annular space reduces gradually, although this occurs more slowly than in brine because the density of the product is lower (of the order of  $900 \text{ kg}\cdot\text{m}^{-3}$  for oil, and  $500 \text{ kg}\cdot\text{m}^{-3}$  for LPG).

At a given depth, the pressure in the annular space is higher than the pressure in the central tube. The difference is greatest at ground level, where, as in our example, it is 3 MPa (for oil storage) or 7 MPa (for LPG storage). At the wellhead, the stored product applies pressure to the valve controlling the annular space. If this valve fails, the product is ejected suddenly, and the brine level in the central string drops until a new balance is reached (in Texas emergency shutdown valves must be installed on the product and brine sides of each liquefied hydrocarbons storage well, Texas Railroad Commission TAC §3.95 [2]; this does not apply to crude oil storage facilities).

For an oil-storage cavern, with an oil density of  $900 \text{ kg}\cdot\text{m}^{-3}$  and with the initial interface at a depth of 1000 m, the top level of the brine in the central tubing will come to rest at a depth of  $h = 250 \text{ m}$  (see Fig. 2). The weights of the brine column and the oil column will then be equal at the interface depth.

If fluids were incompressible, the volume of expelled oil would be small, because the central tube capacity is only a few dozen liters per meter length. In fact, due to the compressibility of oil, brine and the cavern itself, much more oil is expelled. The compressibility factor of brine is  $b_b = 2.7 \cdot 10^{-4} \text{ MPa}^{-1}$ ; the compressibility factor of the cavern is  $b_c = 1.3 \cdot 10^{-4} \text{ MPa}^{-1}$  (this figure can vary, depending on the elastic properties of rock salt and the cavern shape; see Bérest et al., 1999) [3]; and the compressibility factor of the oil can be  $b_o = 6 \cdot 10^{-4} \text{ MPa}^{-1}$ . If  $x$  is the ratio between the stored-oil volume and the cavern volume, the global compressibility is

$$b = b_c + x b_o + (1 - x) b_b \quad (1)$$

Following the wellhead valve failure, the pressure of the entire body of stored fluids (oil and brine) will be reduced by  $DP = 3 \text{ MPa}$  (in the given example). If the cavity contains  $V = 500,000 \text{ m}^3$  of oil and very little brine ( $x \sim 1$ ), then, because of the compressibility, the amount ejected will be  $bV \cdot DP = 6 \cdot 10^{-4} \text{ MPa}^{-1} \cdot 500,000 \text{ m}^3 \cdot 3 \text{ MPa} = 900 \text{ m}^3$ .

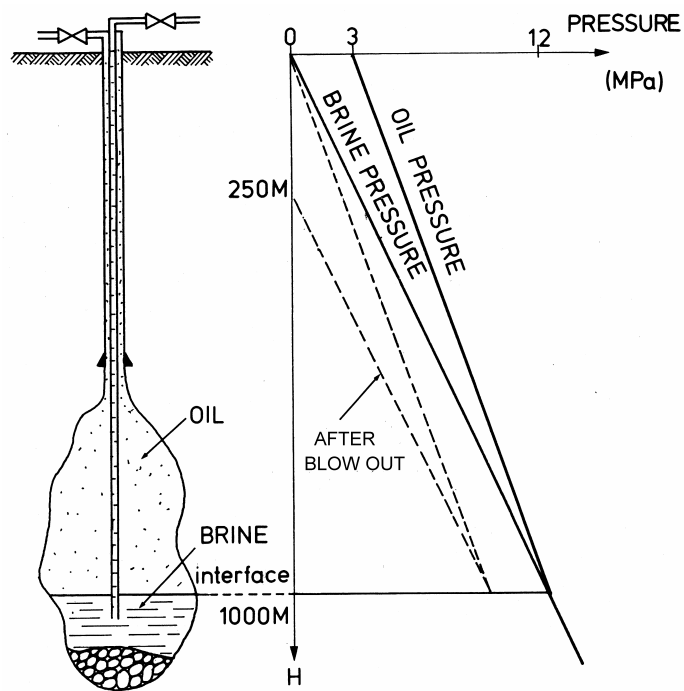
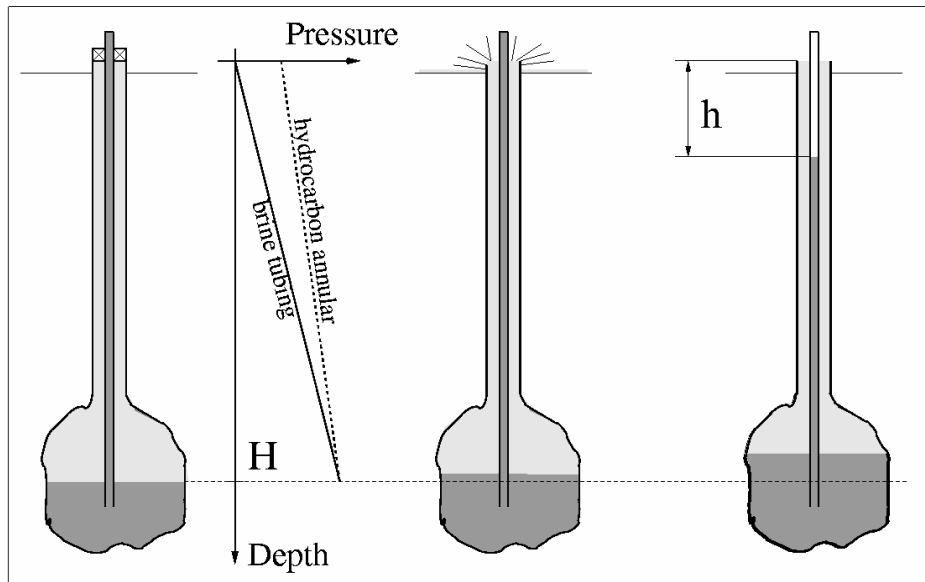

Figure 2 – Pressures distribution before and after a blow out.

For liquefied products, a limited amount of LPG would first be expelled in liquid form. (however, this amount will be larger than in the case of oil, as the compressibility factor of LPG is larger,  $b_p = 3 \cdot 10^{-3} \text{ MPa}^{-1}$ ). This liquid would evaporate gradually after running over the ground, and a heavier-than-air gas cloud would form. Ignition of the cloud is likely.

### 2.2.2 Accident at the West Hackberry Facility (Louisiana, USA)

*Accident Description* — The West Hackberry salt dome is near the Mexican Gulf in southern Louisiana (USA). In 1977, the U.S. Department of Energy (DOE) acquired a number of cavities that had provided brine for the chemical industry. These cavities now are used as a part of the Federal Program for a Strategic Reserve of crude oil, or SPR (Furiga, 1983) [4]. The total capacity of the site is 50 million barrels (8 million  $\text{m}^3$ ).

A complete description of the accident that occurred at West Hackberry can be found in DOE (1980) [5]. Additional information has been made available to the authors by DOE.

The accident occurred on September 21, 1978, during operation on one of the wells in the No. 6 cavity (this large cavity has several wells, and withdrawals can be made reasonably quickly). Understanding the causes requires a few comments on the well completion. Completion comprises a 12.75-in (32.4 cm) casing cemented to a depth of 2632 ft (802 m). A 9.62-in (24.4 cm) pipe, 2603 ft (793 m) long, is cemented inside (the pipe was probably added after the “initial” completion to improve oil tightness when the cavity was being converted for storage). A 5.5-in (14 cm) pipe had been used to withdraw the brine when oil is pumped in oil (see Fig. 3). The report states that the work on the well consisted of withdrawing the 5.5-in tube, repairing a leak on the 12.75-in casing, and reinforcing the wellhead equipment.

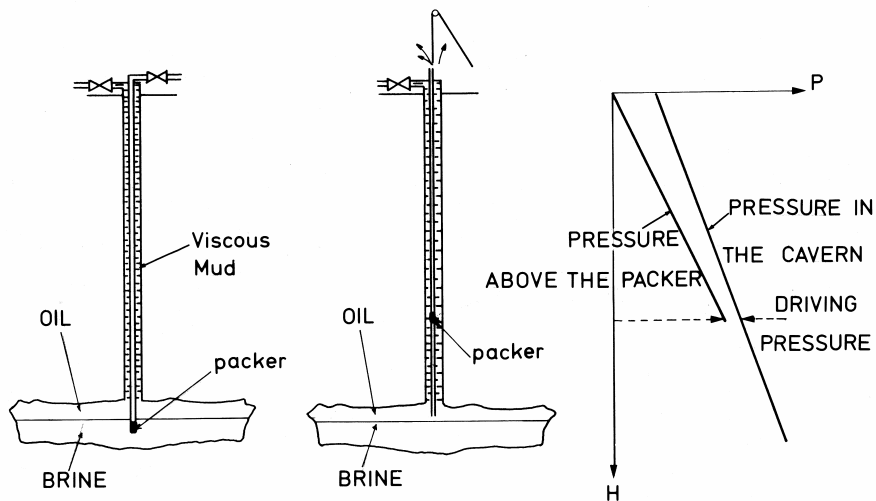

Figure 3 - West-Hackberry blow out. A packer is set at the bottom of the central tube. The pressure differential applied to the packer increases when the central tube is pulled up.

In order to withdraw the 5.5-in pipe, the annular space between it and the 9.62-in pipe had been filled with high-viscosity mud to bring the pressure at the wellhead to zero. Then, a packer was set at the bottom of the 5.5-in pipe to seal it off from the cavity. Work commenced on pulling the 5.5-in pipe; however, after 14 lengths had been removed, the packer slipped, and the oil pushed it up to the surface. As the packer moved upward, the pressure differential on it increased. The packer then shot up to the surface, and the oil geyser continued until all the pressure was dissipated.

An estimated volume of 72,000 barrels of oil (10,000 m<sup>3</sup>) shot up into the air and caught fire, killing one of the drilling crew. The report contains a detailed description of the steps taken to combat the resulting pollution. The DOE report estimates the total cost of the accident at between (1980) US \$14 million and \$20 million.

*Tentative Analysis of the Accident* — The accident at West Hackberry shows that the highest risks do not result from normal running of the facility but, rather, arise from special operations. Poor understanding of the pressure distribution in the fluid columns is probably the main culprit.

In analyzing the accident, we must look beyond the moment of failure of the packer. The basic cause was the delicate operation that was undertaken while the oil was under high pressure and liable to expand violently if any mishap occurred. Although injecting the viscous mud at the top of the well was a good precaution against any failure of the topside valve on the oil-filled annular space, it had absolutely no effect on the dangerous situation at the bottom of the cavity.

A more comprehensive precaution could have been taken by releasing the pressure on the oil so that the pressure at the top of the annular space was removed. This would have caused the top surface of the brine to drop by about one-quarter of the total height. The volume removed would, of course, have been exactly equal to the volume that would have been expelled in an accident. This relatively small amount could easily have been stored temporarily in another cavity on the site, rendering the situation entirely safe.

### 2.2.3 A Liquid Propane Storage Well Fire

This accident, along with the capping and kill plan, is described in Gebhardt et al. (2001) [6]. They point out that “LPG storage (or cavern) wells rarely blow out and/or catch on fire” (p.302). The accident happened in a two-cavern propane storage terminal. The cavern in which the blow-out occurred extended from 1200 ft to 2500 ft. It was believed that the two caverns communicated, due to earlier work in another storage well that led to salt fracturation. At the time of the accident, a “work-over” (Gebhardt et al., 2001, p.303; in fact in this was probably a MIT test) was performed on the second cavern. Nitrogen was used, inducing a large pressure build-up in the two caverns (the wells originally were drilled as oil producers in the late 1950s, four decades before the accident, and a casing leak at shallow depth resulted from the pressure build-up).

Liquefied gas was escaping through the soil in an area as far as 100 ft from the well. Gas ignited and burned with a heavy black smoke. Extinction of the fire was not a viable option, as

dangerous re-ignition was likely. The kill operation used the innovative techniques described in Gebhardt et al. (2001).

#### 2.2.4 Overfilling at Brenham (Texas)

In storing liquid/liquefied products, underestimating the location of the brine/hydrocarbon interface can lead to hydrocarbon access into the brine-filled central tubing, with dramatic consequences if the shut-down emergency system at the well-head happens to be defective. Such an accident occurred in Brenham, Texas, in 1992. Earlier similar events at two other sites are reported by the National Transportation Safety Board (NTSB, 1993) [7], although these did not cause serious damage. This report provided a full account of the Brenham overfilling accident and was used for writing the following brief account.

The Brenham storage facility consists of a 380,000-bbl (60,000-m<sup>3</sup>) cavern filled with LPG (actually, a mixture of propane, ethane, n-butane and other gases). The cavern is linked to ground level by a 13-3/8-in (34.0 cm), 2702-ft (824 m) long cemented casing (Fig. 4). A central tube (2871-ft, 875 m long) allows injection/withdrawal of brine. LPG is injected to or withdrawn from three distinct pipelines. Brine is provided by two above-ground brine ponds. The wellhead is equipped with a shut-down valve. The Brenham station is operated remotely by a dispatcher in Tulsa, Oklahoma.

At 5h43 on April 7, 1992, LPG was injected in the cavern. The brine/LPG interface unexpectedly reached the 1-in (2.54 cm) diameter weep hole located in the lower part of the central tubing, 1 ft (30.48 cm) above the tubing base. The weep hole is supposed to provide warning in case of imminent overfilling. LPG flows into the central tubing, leading to lower density in the fluid central column, partial vaporization and expansion of the lighter gases, pressure drop in the cavern and, ultimately, a larger flow of gas through the weep hole and the tubing base alike. Brine, followed by liquefied gas, sprang at the brine pond surface. Back-calculation proved that 3,000 to 10,000 bbl (500 to 1,600 m<sup>3</sup>) of liquefied gases were expelled.

The release of gas in the atmosphere activated gas detectors at ground level (such activation was a relatively frequent event at this station, often unrelated to an actual gas leak). The dispatcher in Tulsa was not able to interpret correctly the somewhat confusing information delivered by the telemetric system — a unique signal was sent, whatever the number of activated detectors. The shut-down valve (or cavern safety valve) was assumed to immediately react to high pressure level (100 psi, 689 kPa) in the brine tubing at the wellhead, but the system failed.

A heavier-than-air gas cloud, probably 30 ft (9.1 m) high and wide, developed above the station. Employees blocked routes to prevent access to the station. At 7h08, a car entered the foggy cloud and ignited the gas, resulting in a severe explosion (readings of 3.5 to 4 were recorded on the Richter scale), and three people died from injuries received.

Post-accident analysis (NTSB, 1993) identified several causes for the accident:



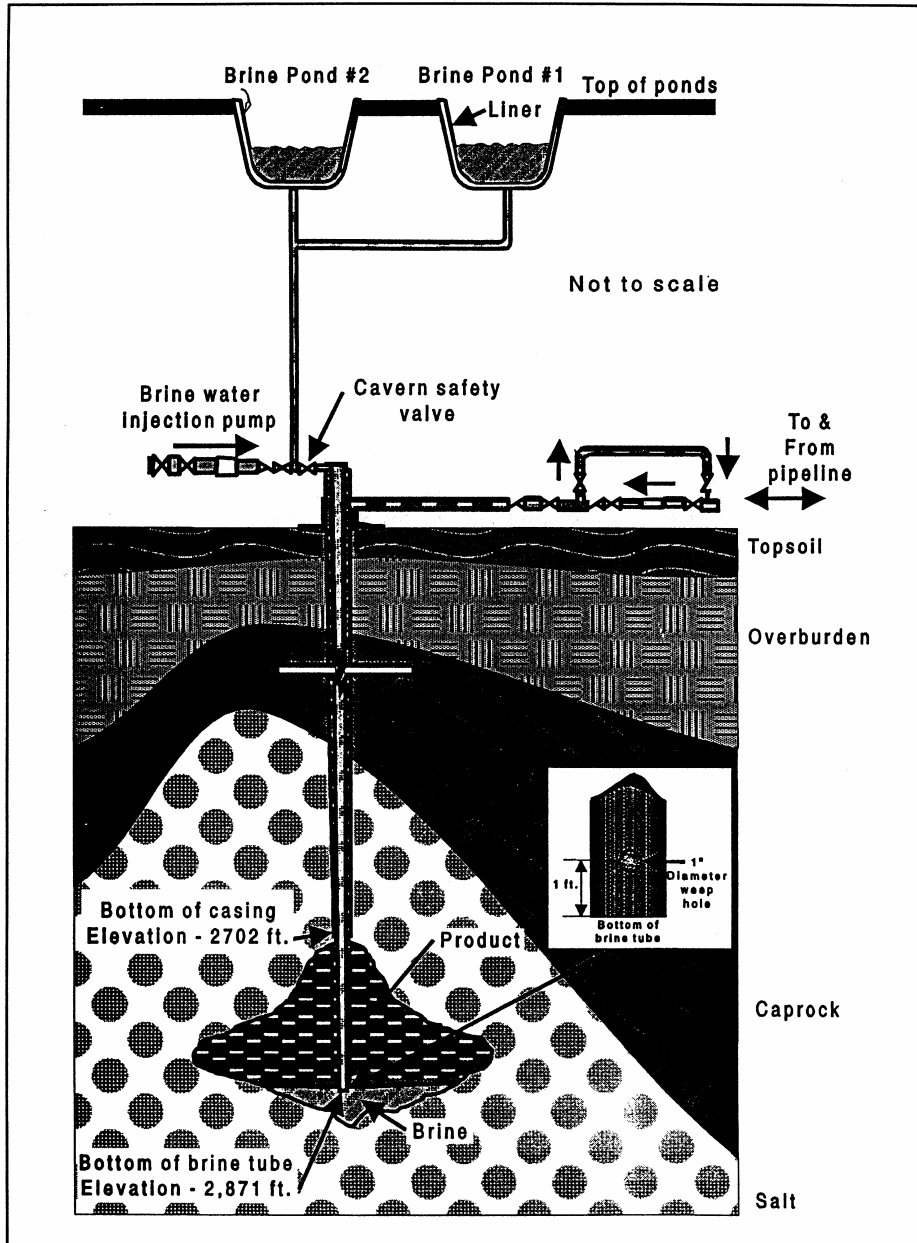

Figure 4 – Brenham cavern (after NTSB, 1993) [7]

1. Underestimation of the amount of stored LPG (330,000 bbl, were actually stored, instead of 288,000 estimated) due to metering inaccuracy, inability to balance gas input/output, poor knowledge of LPG density in the column, and employee

miscalculations (furthermore, pond-saturated brine had been sold to drillers, leading to injection of undersaturated brine and additional dissolution: cavity volume had increased by a factor of 9 from 1981 to 1991); inadequate location of the weep hole, leading to late overfilling warning (the distance between the tubing base and the weep hole was made 6 ft in the later re-design of the facility, instead of 1 ft in the 1992 configuration);

2. Insufficiently detailed information transmitted to the dispatcher board; and
3. Failure of the emergency shut-down system valve (this system included a brine pressure-sensing line; large pressure build-up in the line switched a spring that, when triggered, sent an electrical signal in a chain containing a fusible link whose fusion closed the safety valve. It is extremely likely than one or two manual valves were closed on the sensing line, isolating it from main body of the brine tube and making the emergency system ineffective).

In sour irony, one of the consequences of the gas ignition was that the shutdown valve was activated when heat from the explosion burned the fuse.

After this accident, the Railroad Commission of Texas promulgated new regulations (effective in 1994) mandating that LPG storage caverns be protected by two overfill detection and automatic shut-in methods. A group discussion on cavern overfill detection was conducted by SMRI during its 1996 Spring Meeting (Thiel, 1996) [8].

#### 2.2.5 Natural Gas

For natural-gas storage, little brine is left at the bottom of the cavern, and brine movement is not managed when injecting or withdrawing gas. Gas pressure builds up when gas is injected and drops when gas is withdrawn. In case of wellhead failure, the gas volume of the full cavern would be expelled. This phenomenon probably would be spread over several weeks, depending upon the initial gas pressure and head losses through the well. The eruption would be most spectacular, but probably far less dangerous than an LPG eruption, because natural gas is significantly less dense than air. The gas cloud would move upward rapidly and disperse in the higher atmosphere. In some cases, the cloud could kindle at an early stage, but, if it does not, the risk of explosion would be small.

Rapid depressurization of the cavern, one consequence of well-head failure, can lead to severe pressure build-up at the cavern wall. An estimation of this effect can be found in Rokhahr and Staudtmeister (1993) [9] and Wallner and Eickemeier (2001) [10].

### 3. STORAGE TIGHTNESS

#### 3.1 Introduction

Tightness is a fundamental prerequisite for many underground works where minimum product leakage is required. The goal of tightness has no absolute nature; rather, it depends upon the

specific sensitivity of the environment and the economic context. Air, natural gas, butane and propane are not poisonous from the perspective of underground-water protection: the leakage of sufficiently diluted natural gas into underground water has minor consequences for water quality. This does not apply to other products, such as crude oil.

From the perspective of ground-surface protection, the most significant risk is the accumulation of flammable gas near the surface. In this situation, gases that are heavier than air (propane, ethylene, propylene) are more dangerous than natural gas, but a recent accident in Hutchinson, Kansas, proved that the accumulation of gas in shallow water-bearing formations can lead to severe consequences.

The economic perspective depends basically on the speed of stock rotation and the nature of the products stored. For example, when storing compressed air to absorb daily excess electric power, a loss of 1% per day is considered as reasonable. When storing oil for strategic reasons (e.g., oil that will be used only during a crisis), a loss of 1% per year is a maximum value.

### **3.2 Factors Contributing to the Prevention of Leakage in Salt Caverns**

#### **3.2.1 Salt Permeability**

Rock salt exhibits a very low permeability, because the hydraulic conductivity of its matrix is extremely small (even when the natural salt formations contain a fair amount of insoluble rocks, anhydrite or clay interbedded layers) and because no fractures exist in a massive salt formation (except, perhaps, in some disturbed zones encountered at the fringes of salt domes). Figures as small as  $K = 10^{-22} \text{ m}^2$  to  $10^{-20} \text{ m}^2$  are reported. Several authors believe that most of this (small) permeability is induced by the cavern creation and operation (more precisely, by the tensile or high deviatoric stresses developed at the cavern wall when the cavern fluid pressure is very high or very small). In fact, few reliable in-situ test results are available: permeability is so small that its measurement is beyond the standard techniques used for more permeable rocks (say, rocks with permeability larger than  $K = 10^{-17} \text{ m}^2$ ). For example, experiments performed in an air-intake shaft at the WIPP site provide permeabilities as low as  $K = 10^{-21} \text{ m}^2$  for undisturbed salt (Dale and Hurtado, 1997) [11]. Durup (1994) [12] performed a one-year test in a 1000-m deep well in the Etrez upper salt formation, where anhydrite and clay interbeds are present. This test consisted in the incremental build-up of brine pressure in the cavern. Brine is injected daily to keep the well pressure constant during each step. Assuming Darcy's law, Durup computed an average permeability of  $K = 6 \cdot 10^{-20} \text{ m}^2$  in the 200-m high unlined deeper part of the well. Brouard et al. (2001) [13] compiled a dozen of similar but shorter tests performed in the Etrez lower salt formation and in the Tersanne salt formation: respective back-calculated permeabilities were  $K = 4.6 \cdot 10^{-21} - 1.9 \cdot 10^{-20} \text{ m}^2$  and  $K = 8.6 \cdot 10^{-22} - 3.2 \cdot 10^{-21} \text{ m}^2$ . More recently, at the Etrez site, an 18-month test in a full-sized cavern provided  $K = 2 \cdot 10^{-19} \text{ m}^2$  (Bérest et al., 2001c.) [14]. This larger figure is consistent with the generally accepted effects of scale on rock permeability (Brace, 1980) [15]. How low these figures are is illustrated clearly by a simple example in which  $K = 10^{-20} \text{ m}^2$  and the pressure in the storage cavern is larger than the natural pore pressure in the rock mass by 10 MPa. Then, for a 100,000-m cavern, brine seepage will be  $1 \text{ m}^3$  per year.

As will be seen, fluid seepage from the access well is probably much larger in many cases. In much the same way as for all pressure vessels, leakage is more likely to occur in the “piping” — i.e., the cemented borehole through which the hydrocarbons flow to and from the cavity.

### 3.2.2 Main Factors in the Onset of Well Leakage

Three factors contribute to the problem of leakage in wells: pressure distribution, geological environment, and well architecture. These factors are discussed below.

#### (i) Pressure Distribution

Fluid can only flow from an area of high pressure toward an area of lower pressure. Figure 5 shows pressure distribution as a function of depth. Instead of the pressure at cavern-neck depth, it is convenient to speak of the associated “gradient” (or density) of a fluid column producing the same pressure at the same depth.

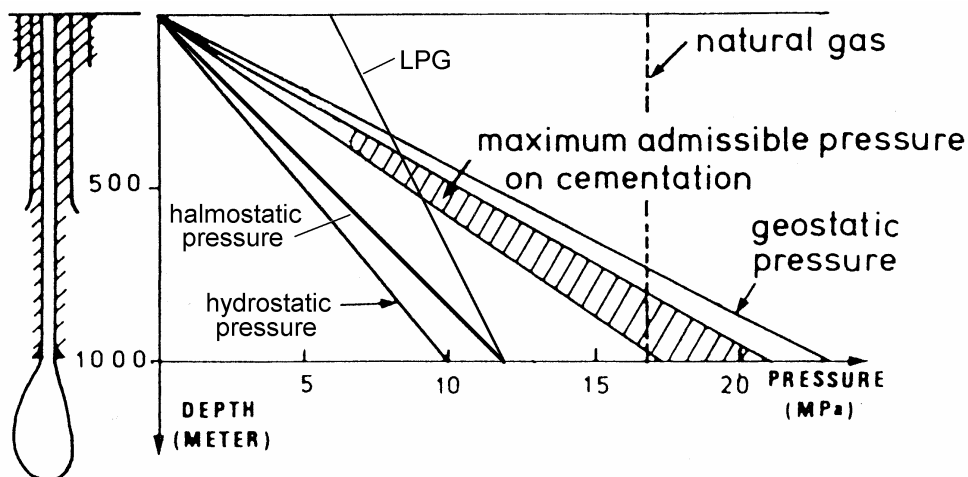

Figure 5 - Pressure distributions when cavern depth is 1000 m. Fluids pressure is larger than geostatic pressure in the upper part of the well.

- The geostatic pressure ( $P_g$ , gradient 2.2) is the natural stress expected in a sedimentary formation with a density of  $2200 \text{ kg}\cdot\text{m}^{-3}$ . Occasionally, anomalous stress is encountered, especially in salt dome flanks, but 22 MPa at a depth of 1000 m is a standard value. This pressure must never be exceeded by any stored fluid, and there must be a safety margin — otherwise, there is a risk of fracturing or of a drastic permeability increase (for analyses of fracturing in salt, see Schmidt (1993) [16], Durup (1994) [12], Rummel et al. (1996) [17] and Rokahr et al. (2000) [18]).

- The hydrostatic pressure (gradient 1) is, in principle, the natural pressure of groundwater in water-bearing strata, although this figure is only indicative.
- The halmostatic pressure ( $P_o$ , gradient 1.2) is the pressure in a saturated brine-filled well open at ground level.
- The maximum pressure, below which a cement-filled annular space will not leak significantly (gradient 1.8-2.0), is a site-specific notion. This pressure must not be exceeded at the casing shoe, where the cement is in direct contact with the stored product.
- The pressure of the stored product at cavern depth ( $P_i$ ) is equal to the halmostatic pressure in caverns storing liquid or liquefied products. For natural-gas storage caverns, the maximum gas pressure often is much larger; the largest admissible value is dictated by the amount of leakage through the cement-filled annular space, as explained in Section 4.3.

(ii) *Geological Formation*

If most of the rock formations through which the well crosses are impervious, the situation is, of course, extremely favorable. Salt domes are frequently surmounted by a very permeable zone (called caprock), where brine easily circulates between the pieces of rock left over from solution of the top of the salt dome. This situation requires special treatment (see the discussion on the Mont Belvieu case, below).

In contrast, soft-impervious formations can have a very favorable effect in that they naturally creep and tend to tighten around the well, improving the bond between the cement and the casing. For example, the salt layers in which the Tersanne natural-gas facility is sited in France is overlain by 600 m of predominantly clayey ground. "Cement Bond Logs" have revealed a significant improvement, attributed to clay creep, with the passage of time.

(iii) *Cementing Workmanship and Well Architecture*

Cementing in gas and oil wells is a "rough and ready" operation, but underground storage engineers work under a higher standard than is typical in most oil-industry operations. This has led to many improvements in the techniques usually employed in oil drilling (e.g., the use of admixtures, recementing, leak tests). The various logs kept allow the quality of cement-steel or cement-rock bonding to be assessed (ATG Manual, 1985 [19]; Jordan, 1987 [20]; Kelly and Fleniken, 1999 [21]).

The architecture of the borehole is just as important, and errors are easier to identify. It is common knowledge that oil wells usually do not have only a single casing cemented into the ground. Drilling proceeds in stages, and, in each stage, a casing is run and cemented into that level, with each casing having a smaller diameter than the preceding one. By the time the hole has reached its final depth, there are several concentric casings at the top, gradually decreasing in number lower down.

Obviously, this is beneficial for safety in a storage environment. We have seen that the positive pressure differential of products in a well increases toward the surface. It is also true that, near the surface, any leakage beginning at the junction between two casing lengths will be channeled in the cemented annular space between the inner casing and the outer casing. A leak can rise up the cemented annular space between the two casings, but it will come out at the surface at the hole collar, where it is easy to detect and treat.

The architecture of the well and the number and length of steel casings generally are selected with reference to the actual objectives of the drilling operations. These may be to shore up a hole through weak strata or to prevent communication between two aquifers at distinctly different pressures. Clearly, the objectives must also include leakage prevention and may require a more complicated architecture to isolate a stratum that was not troublesome for the driller but which might later promote leakage through a single damaged casing. In particular, the last two cemented casings must be anchored in the salt formation or in an overlying impermeable formation. As Thoms and Kiddoo (1998, p.114) [22] state, "Once in the porous sand formations, the gas can readily migrate (...). This has happened in US Golf Coast wells (...). Thus two casing strings are now 'cemented' into the salt." In Texas, Rules §3.95 and 3.97 of the Texas Railroad Commission, the authority in charge of oil matters in the area, make this design mandatory for wells completed later than 1993.

Gaz de France has opted for the most comprehensive solution by specifying double-tubing with a central string inside the inner casing (Fig. 6) at all gas sites. The annular space between them is plugged at the bottom and filled with fresh water. Any gas leak from the central string immediately results in a pressure build-up in the annular space, which is detected easily at ground level. The drawback of this solution is that it slightly reduces the effective diameter of the hole, as well as the rate at which products can be withdrawn. However, it has a very great advantage in that leaks can occur only at the tip of the cemented casing.

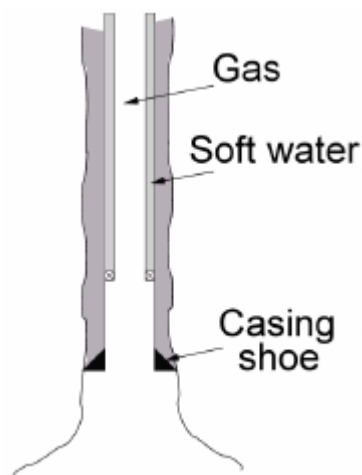

Figure 6 - Water-filled annular space in GDF natural gas storages.

### 3.3 Mont Belvieu Accident

#### 3.3.1 The Accident

This accident occurred in 1980 at Mont Belvieu, Texas, where a salt dome is used by a large number of companies and where several dozen cavities had been solution-mined. This site has the largest storage capacity for petrochemical products anywhere in the United States.

A drop in pressure was recorded on September 17, 1980, in one of the cavities containing liquefied petroleum gas. On October 3, gas (70% ethane, 30% propane) that had accumulated in the foundation of a house in the area exploded as a result of a spark from an electrical appliance. The cavity in which the pressure had dropped was then filled with brine. In the days that followed, gas appeared haphazardly around the area, and approximately 50 families had to be evacuated. Holes were drilled into the water tables above the salt to find and vent the gas.

In the absence of fully detailed information, we make a credible reconstruction of the accident based on a typical propane storage facility in a salt dome.

#### 3.3.2 Analysis of the Accident

A salt dome is a geological structure in which an originally horizontal bed of salt has risen toward the surface by puncturing the overlying strata. When the dome reaches water-bearing layers, the top may dissolve, leaving a cap of insoluble rock surrounded by brine (Fig. 7).

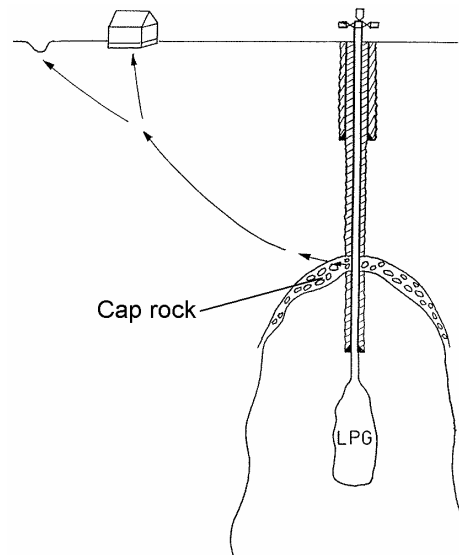

Figure 7 – The Mont Belvieu (Texas) accident. After 22 years under operation, the last cemented casing becomes leaky. After the accident it was decreed that future wells be equipped with two casing strings into the salt.

If the well casing is leaky (e.g., at a joint between two lengths or because of corrosion; the well “at fault” at Mont Belvieu dated from 1958), the product can escape toward the caprock. Leakage is faster when there is a high pressure differential between the product and the groundwater. The differential may be significant if the caprock lies much higher than the storage cavity.

Because of its low density, propane tends to rise to the surface, either through the cement along the outside of the casing or by dispersing in the overlying ground. This happens, for example, if it finds a sufficiently pervious water-bearing layer just below the surface. The gas can accumulate in building foundations, emerge at streams and similar low-lying ground or come up through faults and joints, daylighting at the surface several hundred meters from the well head.

### 3.3.3 Regulations in Texas

The Railroad Commission of Texas established rule 74 effective April 1, 1982, which specified cavern integrity testing requirements (Johnson and Seni, 2001) [23]. In 1993 the Commission decreed that future wells be equipped with two casing strings cemented into the salt (Texas Railroad Commission, TAC Title 16 Part 1 §3.95 and 3.97) [2]. Integrity tests are discussed below.

A similar — but more severe — accident occurred recently (February 2001) in Hutchinson, Kansas. A complete picture of this accident is not yet available. Apparently, a natural-gas storage well became leaky, and natural gas migrated underground to a town 10 km from the well. The gas erupted, resulting in two deaths.

## 3.4 Tightness Testing

### 3.4.1 Introduction

In general, when testing a pressure vessel, pressure is built up in the vessel to a level slightly above the maximum operating pressure. Leaks are detected through visual inspection or, more accurately, through records of pressure evolution. A dramatic pressure fall is a clear sign of poor tightness. A key question concerns the allowable rate of pressure decrease; it is usually fixed according to experience rather than through a more scientific understanding of the mechanisms of pressure decrease.

Selecting too high a test pressure is not recommended, even if such a choice provides better confidence in vessel tightness. For example, when storing natural gas in an underground facility, the maximum operating pressure tends to be close to the geostatic pressure, which is the maximum conceivable fluid pressure in an unlined underground opening. In this case, only a small margin is left for selecting a test pressure. When a vessel is decompressed after testing, the pressure decrease rate is also a matter of concern. This rate can be high, especially when a stiff test fluid is used; however, too fast a pressure release induces large tensile stresses and pore pressure gradients, which can be damaging to the rock formation or cemented wells. Generally, a moderate post-test pressure decrease rate is recommended.



When available at a reasonable cost, a stiff, non-explosive and non-polluting test fluid is preferred so that the consequences of a leak during testing are benign. In addition, when a stiff fluid is used, a small leak causes a significant and easily detectable decrease in the pressure rate, providing a high sensitivity for the test system. The compressibility factor of a brine-filled salt cavern is approximately  $\beta = 4 \cdot 10^{-4} \text{ MPa}^{-1}$  (Bérest et al., 1999) [3]; in a  $100,000\text{-m}^3$  closed cavern, a  $1\text{-m}^3$  fluid leak leads to a pressure drop of  $2.5 \cdot 10^{-2} \text{ MPa}$ , which is an easily detectable figure. Conversely, accurate testing of a salt cavern filled with natural gas is almost impossible. If the gas pressure is, say,  $P = 20 \text{ MPa}$ , the compressibility factor of a gas-filled cavern is in the range  $\beta_g = 1/P = 5 \cdot 10^{-2} \text{ MPa}^{-1}$ , a figure which is too high to allow any accurate flow measurement of a leak.

A slightly different test procedure is possible in deep salt caverns. The cavern-plus-well system is similar to the ball-plus-tube system used in a standard thermometer or barometer. Compared to a huge cavity, the well appears as a very thin capillary, and tracking displacements of a fluid/fluid interface in the well allows high sensitivity to fluid volume changes to be obtained. When measuring interface displacement, an accuracy of  $\Delta h = 15 \text{ cm}$  for a  $20\text{-l/m}$  well cross-section is easily achieved, which means that brine movement of  $v = 3 \cdot 10^{-2} \text{ m}^3$  is detectable, even though the cavern volume can be  $V = 100,000 \text{ m}^3$ .

### 3.4.2 Tightness Tests in Salt Caverns

A Mechanical Integrity Test (MIT) is used to test cavern tightness. Two types of the MIT are currently used; these are described below (see Fig. 8).

- The Nitrogen Leak Test (NLT) consists of lowering a nitrogen column in the annular space below the last cemented casing. The central string is filled with brine, and a logging tool is used to measure the brine/nitrogen interface location. Two or three measurements, generally separated by 24 h, are performed; an upward movement of the interface is deemed to indicate a nitrogen leak. Pressures are measured at ground level, and temperature logs are performed to allow precise calculation of nitrogen seepage (see, for instance, Thiel, 1993) [24]; in 1998, the SMRI organized a technical class dedicated to the Mechanical Integrity Testing of Brine Production and Storage caverns to provide a comprehensive assessment of the state of the art; proceedings are available from SMRI).
- The Fuel-Oil Leak Test (FLT) is more popular in Europe than in the United States. It consists of lowering a fuel-oil (instead of nitrogen, as for the NLT) column in the annular space. During the test, attention is paid to the evolution of the brine and fuel-oil pressures as measured at the well head. A severe pressure-drop rate is a clear sign of poor tightness. In addition, the fuel-oil is withdrawn after the test and weighed, allowing comparison with the weight of the injected fuel-oil volume.

The FLT is generally used before the cavern is leached out; the NLT is used for full-size cavern testing.

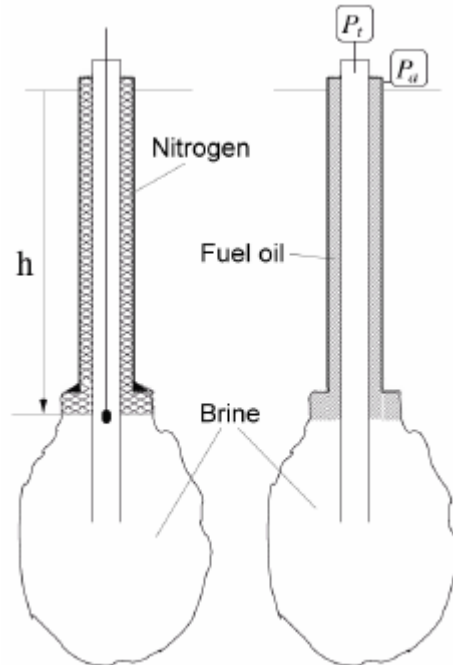

Figure 8 - Nitrogen (left) versus Fuel-Oil (right) Leak Tests (in the former, the nitrogen/brine interface is tracked through a logging tool; in the latter, tubing and annular pressures are continuously recorded at the well head during the test).

### 3.5 The Fuel-Oil Test

The Fuel-Oil Leak Test is simpler than the Nitrogen Leak Test; it is a little less demanding from the perspective of checking tightness but has several advantages.

- For a given cavern test pressure, fuel-oil, which is heavier than nitrogen, involves lower well-head pressures.
- No logging tool is required, and the recording can be performed continuously at the well head for the duration of the test.
- Gauging the fuel-oil weight before and after the test can be performed easily.

Discriminating between the actual leak (i.e., from the well to the formation) and the apparent leak (i.e., from the cavern to the salt formation) can be accomplished through a simple — but accurate — method (see Bérest et al., 2001b) [25]. The only weakness of this test lays in the high viscosity of fuel oil (when compared to the viscosity of nitrogen), which impairs test accuracy (in comparable conditions, a gas leak is much larger than a liquid leak).

## 3.6 The Nitrogen Leak Test

### 3.6.1 Principle of the Test

The Nitrogen Leak Test (NLT) is probably the most popular well-test method. Nitrogen is much less viscous than liquid, allowing very small leaks to be detected. In the NLT (Fig. 8), the cavern is filled with brine (stored products are withdrawn before the test) and pre-pressurized so that the test pressure can be reached after nitrogen is injected in the annular space. When the nitrogen/brine interface reaches mid-depth, a first interface logging is performed. Then, the interface is lowered to its final position, below the last casing shoe in the cavity neck, where the horizontal cross-section ( $S$ ) ranges from one to a few square meters. The advantage of such a location is that it allows the well and a significant part of the cavern neck to be tested together. A significant drawback is that the larger the  $S$  cross-section, the smaller the resolution. A downhole temperature log is run at the beginning and at the end of the test period, which lasts a minimum of 72 h. It is recommended that three interface measurements be performed: immediately after the nitrogen injection; 24 h later; and, last, at least 24 h after that.

### 3.6.2 Accuracy of the Test

The roughest (“naive”) interpretation consists of measuring the interface depth variation,  $dh$ , during period  $dt$ . Taking into account the horizontal cross-sectional area at interface depth, the nitrogen seepage rate,  $\dot{m}/r$ , is assumed to be:

$$\dot{m}/r = Q = \Sigma dh / dt \quad (2)$$

In this example, since interface-depth measurements have an accuracy of 15 cm, the resolution of the method is 1.5 m<sup>3</sup>/day. This relatively poor resolution is due to the large cross-sectional area,  $S$ , at interface depth.

This naive interpretation, however, suffers from a more fundamental flaw: it is assumed that the nitrogen leak is the only factor able to lead to interface displacement — an assumption that is misleading, as will be discussed later. A better interpretation consists of taking temperature and pressure variations into account:

$$\frac{dm}{m} = \frac{dP}{P} + \frac{dV_g}{V_g} - \frac{dT}{T} \quad (3)$$

where  $dV_g = \Sigma dh$  is the gas-volume variation. Average brine and temperature variations can be measured through pressure-temperature logs, but the accuracy of these measurements is often not better than that for measuring volume.

A theoretical analysis of the NLT and a description of a test aimed at validating the NLT can be found in Bérest et al. (2001b) [25]. They suggest that one must distinguish between the “apparent” leak (bluntly deduced from the observed displacement), the “corrected” leak

(obtained when taking into account well-known and easily quantifiable mechanisms contributing to the apparent leak, such as changes in temperature), and the “actual” leak, which can differ greatly from the apparent leak. In fact, the corrected leak is likely to be smaller than the observed leak, as the initial pressure build-up at the beginning of the test triggers various phenomena that, according to the Le Chatelier principle, tend to restore the preexisting equilibrium pressure and create the illusion of a leak.

### 3.6.3 Maximal Admissible Leak Rate

One key question concerns the amount of leakage a cavern should be allowed. A clarifying point has been made by Crotogino (1995) [26] in a report prepared for the SMRI that was based on industry responses. Crotogino makes a distinction between the Minimum Detectable Leak Rate (MDLR, the measurement-system resolution) and the Maximum Admissible Leak Rate (MALR). He suggests that the test be designed in such a way that the MDLR be one-third of the MALR. The proposed MALR is 150 kg/day (or 270 m<sup>3</sup> per year when pressure and temperature are, respectively, 17 MPa and 300 K at cavern depth). Thiel (1993, p.379) [24] suggested similar figures: “(...) 160 m<sup>3</sup>/year (1000 bbl/year) test resolution has become somewhat of a standard.”

## 4. CAVERN STABILITY

### 4.1 Case Studies

All solution-mined cavities converge as they gradually, and quite slowly, shrink. Prediction of volume loss rate has led to numerous works, but it is still a controversial matter. A brief discussion of the various theoretical approaches is provided at the end of this chapter, but a few facts are presented here.

1. Subsidence is experienced at several sites (Fig. 9, 10, 11) — see for instance Menzel and Schreiner (1983) [27], Ratigan (1991) [28], Durup (1991) [29], and Van Sambeek (1993) [30]. However, no damage at ground level resulting from cavern convergence has been experienced. Nguyen Minh et al. (1993) [31] and Quintanilha de Menezes and Nguyen Minh (1996) [32] proved that, at the Tersanne site, where cavern convergence is relatively large, the volume of the subsidence trough at ground level was 60% of the estimated volume loss of the cavities after 6 years of operation. In this 1400-m deep vertical salt formation, the subsidence rate was approximately 1 cm per year.
2. Convergence rates in shallow, fluid-filled caverns are slow. Brouard (1998) [33] measured brine outflow from the cavern well head in a brine-filled, 950-m deep, 7500 ± 500-m<sup>3</sup> cavern at the Etrez site. The test was performed 15 years after cavern leaching: in this small cavern, the effects of brine thermal expansion become negligible after such a length of time, and the 7.2-liter/day brine outflow can be attributed to cavern convergence. The relative volume loss rate was  $\dot{V}/V = - 3 \cdot 10^{-4}$  year<sup>-1</sup>, a very small figure.

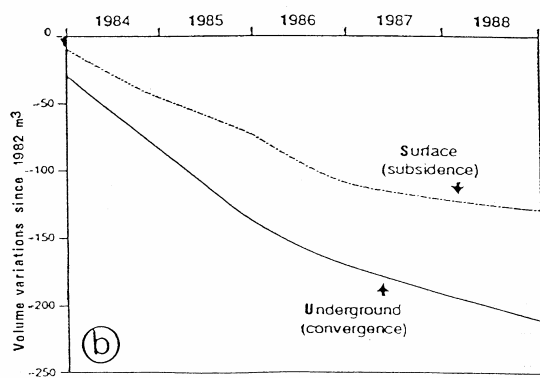
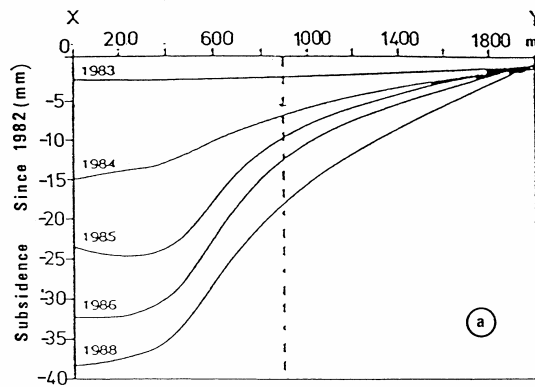
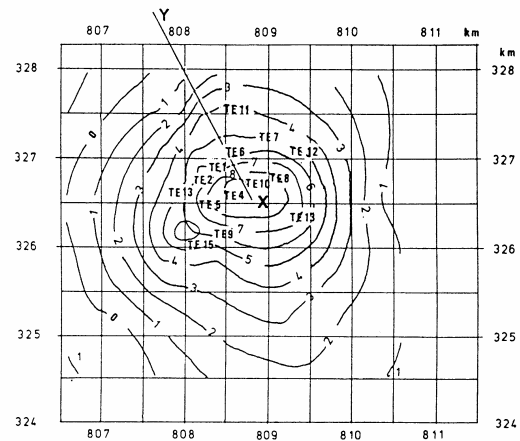

Figure 9 – Subsidence in the Tersanne site (after Durup, 1991) [29].  
 Subsidence trough volume is 60% of caverns volume loss.

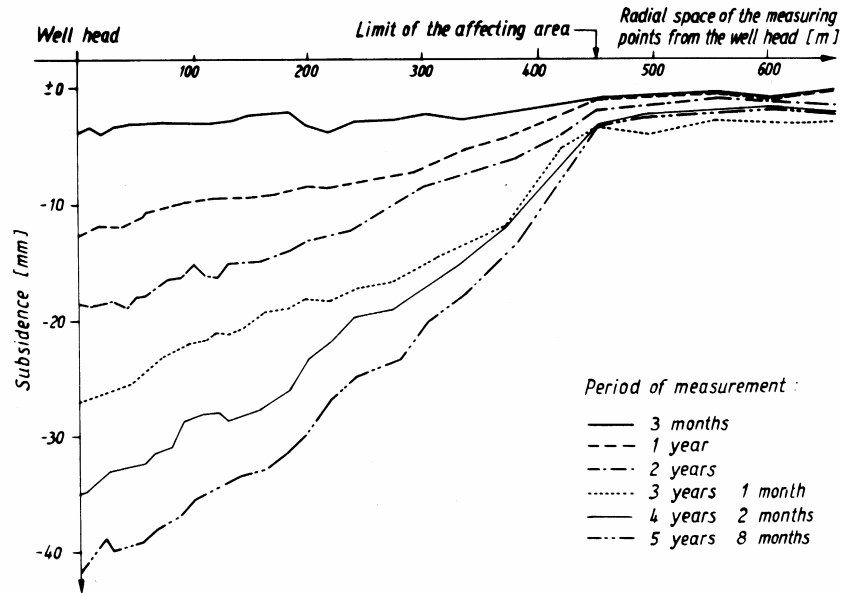

Figure 10 – Subsidence in the Bernburg (Germany) site (after Menzel and Schreiner, 1983)[27].  
Cavern depth is 500-650 m, cavern useful volume is  $10^5$ - $3 \cdot 10^5$  m<sup>3</sup>.

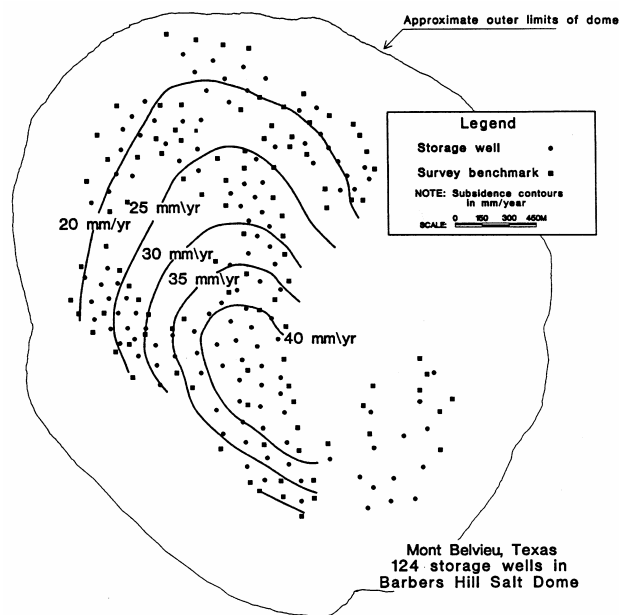

Figure 11 – Subsidence in the Mont Belvieu (Texas) site (after Ratigan, 1991) [28].  
In this site, 124 caverns are operated.

3. Some natural gas storage facilities have experienced large losses of volume. The Eminence salt dome caverns (Mississippi) have experienced large changes after a relatively short period of time. According to Baar (1977, p.143-144) [34], “the unexpected anomalies in the closure of the first cavern included a rise of the cavity bottom by 120 ft (36 m) and a cavity storage space loss possibly up to 40%”.

Cavern 1 was leached out “on 21.12.69, dewatering was finished on 8.10.70. On 25.05.70, the cavity bottom was at a depth of 6560 ft”, and the cavity top was at 5750 ft (1725 m). After dewatering, the gas pressure was reduced to 1000 psi (7 MPa) and kept at this value for more than 2 months, before it was built up to about 4000 psi (28 MPa). Then, a second pressure cycle began; after the second cycle, on 28.04.72, “the cavity bottom was at 6408 ft, which means a loss of 152 ft (45.6 m) in about two years. On 23.6.72 cavity had been refilled with brine and a sonar was taken after refilling” (Fig. 12 and 13). Additional information is provided in Coates et al. (1983) [35].

Bérest et al (1986) [36] suggested that the asymmetrical deformation of this cavern (i.e., large bottom upheaval and small roof displacement) was due to the higher temperature and the higher overburden pressure at the bottom than at the top of this slender cavern.

4. Röhr (1974) [37] provides some data related to the gas-storage cavern Kiel 101. This cavern had been leached out between the depths of 1305 m and 1400 m. Due to the high content of insolubles, less than 60% of the total 68,000 m<sup>3</sup> was available for storage. “Starting about 1.11.67, the pressure at the roof of the cavity was lowered from 15.6 MPa to practically zero by pumping the brine out of the access well” (Baar, 1977, p.147) [34]. Figure 14, presented by Baar (1977), shows the internal pressure at the roof of the cavern dropping from 13.1 MPa to 6.5 MPa in 5 days, then building up (when pumping stops) to 8 MPa (the roof broke at this stage) during a 35-day period. A sonar log performed at the end of this period proved that the sonar volume had decreased from 36,600 m<sup>3</sup> to 32,100 m<sup>3</sup>. An additional loss of 1900 m<sup>3</sup> in usable cavern volume was observed 5 months later.
5. Boucly and Legreneur (1980) [38] and Boucly (1984) [39] provide data on Te02, a gas-storage cavern at the Tersanne site in southeastern France. This pear-shaped cavern was leached out from November 1968 to February 1970; dewatering took place from May to September 1970. The initial usable volume at that time was 91,000 ± 2700 m<sup>3</sup>, and the additional volume of sedimented insolubles was 22,000 m<sup>3</sup>. From September 1970 to July 1979, the mean pressure in the cavity remained comparatively high (18 MPa). Gas pressure ( $P_i$ ) history is important in this context and can be summarized as follows:

? 8 MPa ≤  $P_i$  ≤ 10 MPa for a cumulated period of 163 days;

? 10 MPa ≤  $P_i$  ≤ 15 MPa for 556 days;

? 15 MPa ≤  $P_i$  ≤ 20 MPa for 1059 days;

? 20 MPa ≤  $P_i$  ≤ 22 MPa for 1549 days.

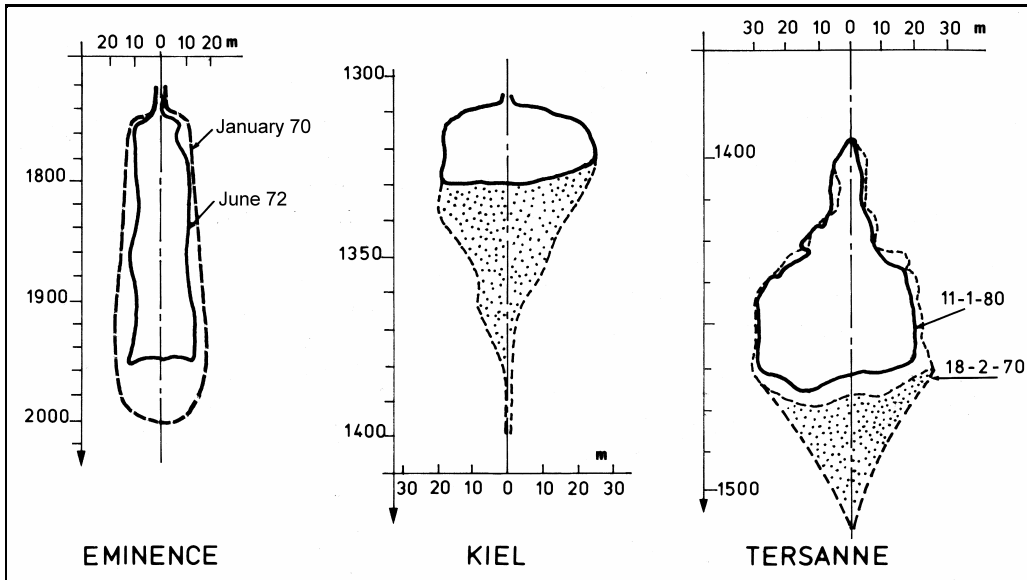

Figure 12 - Creep effects in Eminence (Mississippi), Kiel (Germany) and Tersanne (France). Dotted surfaces represent insolubles sedimented at the cavern bottom.

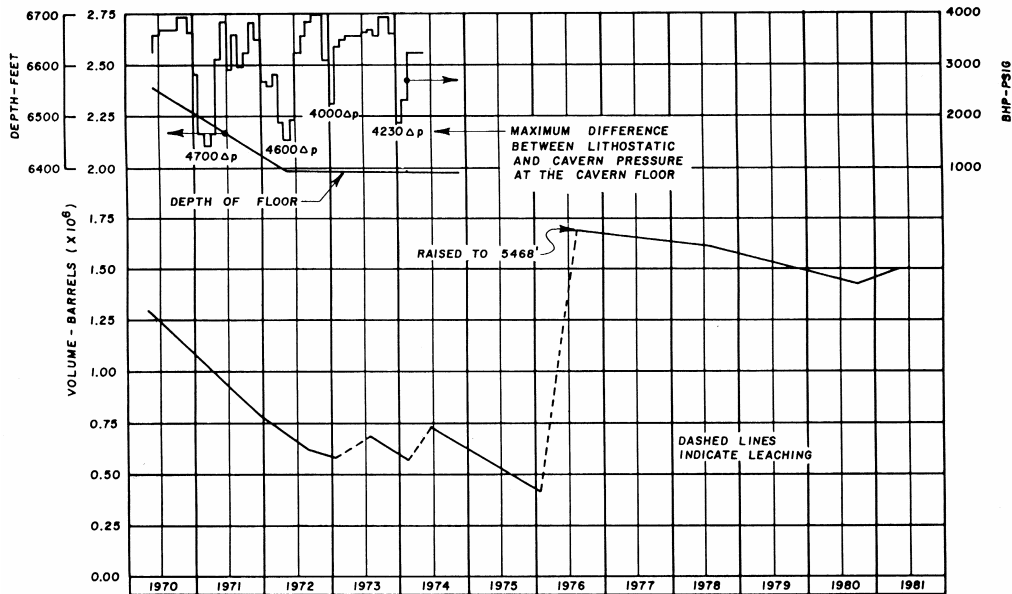

Figure 13 - Volume and pressure as functions of time for Eminence cavern #1 (after Coates et al., 1983 [35] ; original source is Fenix and Scisson, 1980 [40]).



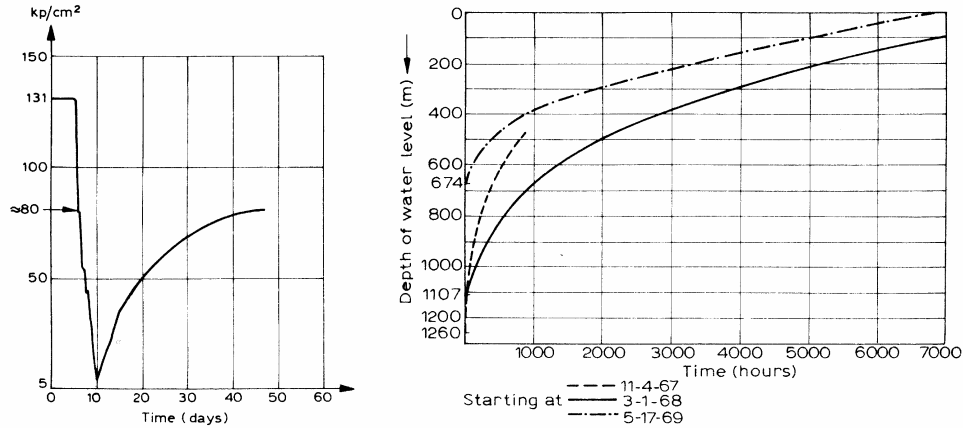

Figure 14 – Internal pressure at the roof of the Kiel 101 cavern during dewatering of the access well in November 67 and brine level rise in the well after brine level was lowered at the indicated times, after Baar (1977) [34] ; original sources are Dreyer (1972) [41] and Röhr (1974) [37].

After nine years under operation, the volume available to gas had decreased by about 35% (Fig. 12).

6. Smaller convergence rates were observed by Staupendahl and Schmidt (1984) [42] in a 980-m deep cavern kept at atmospheric pressure. The relative horizontal cross-section area loss was 0.5-0.6% per year. Quast and Schmidt (1983) [43] describe a 400,000-m<sup>3</sup> slender cavern (1000 m to 1280 m in depth). After 4 years of gas-storage operation during which the cavern pressure varied between 2.5 MPa and 16 MPa, the cavern shape, as measured by sonar logs, had not undergone any substantial changes (the accuracy of this measurement is a few percent). An interesting attempt to compare cavern convergences reached after each injection-withdrawal cycle in a gas-cavern of the Epe site was presented by Denzau and Rudolph (1997) [44].

#### 4.2 Temperature and Pressure Influences

At first sight, these data may seem somewhat erratic. However, even if site-specific rock properties play some role, the data infer that the driving force for cavern shrinkage is the gap between the overburden pressure at cavern depth (approximately  $P_{\text{y}} \text{ (MPa)} = 0.022 H \text{ (m)}$ , where  $H$  is cavern depth) and the cavity internal pressure ( $P_i \text{ (MPa)} = 0.012 H \text{ (m)}$  in an liquid-filled cavern — significantly less in a nearly empty gas-filled cavern). In fact, for a gas-filled cavern, the entire pressure history (i.e., the durations of the periods during which pressure is high or low) is of importance. Furthermore, laboratory tests prove that salt creep is temperature-sensitive which means that cavern depth is influential, due both to higher temperatures and higher pressure gaps in deeper caverns. The following simple uniaxial model captures the main features of rock behavior:

$$\dot{\epsilon} = - A \exp \left( - \frac{Q}{RT} \right) \sigma^n \quad (4)$$

where  $e$  is sample height reduction,  $s$  is the applied stress,  $T$  is the (absolute) rock temperature, and  $A$ ,  $Q/R$  and  $n$  are model parameters. Values of the three constants have been collected by Brouard and Bérest (1998) [45]: for twelve different salts, the constant  $n$  is in the range  $n = 3-6$ , illustrating the highly non-linear effect of the applied stress. This model leads to closed-form solutions for spherical or cylindrical caverns, idealized shapes which give a valuable approximation in the case of many actual caverns:

$$\dot{V}/V_{sphere} = - \frac{3}{2} A \exp \left( - \frac{Q}{RT} \right) \left[ \frac{3}{2n} (P_{\infty} - P_i) \right]^n \quad (5)$$

$$\dot{V}/V_{cyl} = \dot{V}/V_{sphere} (2/\sqrt{3})^{n+1} \quad (6)$$

These formulae have been given and discussed by Hardy et al. (1983) [46] and Van Sambeek (1990) [47]. They provide useful orders of magnitude; notably, they clearly explain that the volume loss rate in a fluid-filled cavern is larger by two orders of magnitude when cavern depth is doubled.

However, these simple approximations are poorly suited for gas-filled caverns, where cavern gas pressure varies significantly with time. Model (4) does not capture the transient effects, which play a major role in this context. Vouille et al. (1984) [48] and Hugout (1988) [49] have proposed the following Lemaitre or Menzel-Schreiner model which predicts the following evolution of the sample deformation rate during a uniaxial compression test:

$$\dot{e} = - K s^a t^b \quad (7)$$

This model provides good results when varying pressure is applied to the cavern wall.

The gas-cavern case has motivated various studies, as this case is the most demanding from the perspective of mechanical stability: gas caverns are often deep (which allows high gas pressure when the cavern is filled), and they experience very low gas pressure when the cavern is nearly empty. Analyses can be found in Lux and Rokahr (1980) [50], Schmidt and Staudtmeister (1989) [51], Menzel and Schreiner (1989) [52], Krieter et al. (1997) [53], Klafki et al. (1998) [54], and DeVries and Nieland (1999) [55].

Obviously, rock mechanics problems are not exhausted by the above simple remarks. Several other parameters play important roles, including roof shape (a large-spanned flat roof must be avoided, as it is prone to spalling), distance to the top of the salt formation, spacing between two adjacent caverns, and distance from the dome flanks (which are often the seat of anomalous stresses). Actual geometrical parameters for a wide collection of real cavern sites have been collected by Thoms and Gehle (1988) [56]. Many rules have been suggested in the literature, sometimes based on 3D calculation. Experts opinion varies widely with regard to the stress criterion above which salt can be considered to be damaged. For those interested in the more fundamental aspects of salt rock behavior, a few additional comments are provided below.

### 4.3 Mechanical Behavior of Salt

The mechanical behavior of salt exhibits a fascinating complexity, and several aspects of it are still open to discussion — see, for instance, the proceedings of the five Conferences on the Mechanical Behavior of Salt (Hardy and Langer, 1984 [57] and 1988 [58]; Hardy et al., 1996 [59]; Aubertin and Hardy, 1997 [60]; Cristescu and Hardy, 2002 [61]).

With regard to the behavior of a salt cavern, the situation is somewhat paradoxical. On one hand, a considerable amount of laboratory data is available (no other rock has given rise to such a comprehensive set of laboratory experiments, motivated, to a large extent, by the specific needs of nuclear-waste storage). Also, various dedicated numerical models, able to accommodate sophisticated constitutive laws and to perform 3D simulations, have been written. On the other hand, however, a deep underground cavern is accessible only through the thin metallic tube that links it to the ground surface. Convergence data are rough, scarce, and sometimes inaccurate, and they make validation of sophisticated models uncertain.

Some distinct features of rock salt behavior can be identified: salt behavior is elastic-ductile when short-term compression tests are considered; it is elastic-fragile when tensile tests are considered (the same can be said of effective tensile tests — i.e., when a confining brine pore pressure larger than the smallest applied compressive main stress is applied). In the long term, salt behaves as a fluid in the sense that it flows even under very small deviatoric stresses, but, even in this case, steady-state creep (reached after several weeks or months) must be distinguished from transient creep (which is effective during a several week period after mechanical loading is applied).

Interesting attempts have been made to capture these various features in a unique comprehensive mechanical-behavior model (Cristescu, 1993 [62]; Cristescu and Hunsche, 1996 [63]; Munson, 1997 [64]; Aubertin et al., 1998 [65]; Weidinger et al., 1998 [66]; Hampel et al., 1998 [67]). However, the number of parameters to be identified through laboratory tests for such models is often out of practical reach. From an engineering perspective, it is easier (and less costly) to select typical situations in which one or the other of the various features of complex salt behavior plays a pre-eminent role, allowing other aspects of importance in other contexts to be disregarded.

When computing the amount of fluid expelled from a cavern as a consequence of a blow-out or the amount of brine to be injected in a cavern to pressurize it, the compressibility (i.e., elastic properties) of the fluid-plus-cavern system is important (Bérest et al., 1999) [3]. When the very long-term behavior of a constant-pressure liquid-filled cavern is to be discussed, steady-state creep behavior provides a good approximation of the overall trend.

When performing a tightness test, at the beginning of which cavern pressure is rapidly built up, short-term transient creep must be taken into account; when neglected, it can lead to gross misinterpretation of the test results (Hugout, 1988 [49]; Bérest et al., 2001b [68]). When natural gas caverns, operated at varying pressures, are examined, transient creep (Aubertin et al., 1993 [69]; Munson, 1999 [70]) and the duration of each pressure step must be taken into account. Finally, rock damage and coupled hydromechanical behavior must be considered both when the cavity pressure is very low (Cosenza and Ghoreychi, 1996 [71]; Pfeifle and al., 1998 [72]; Pfeifle and Hurtado, 2000 [73]) or close to geostatic pressure (see Part 4).

Many other aspects are still open to discussion — for instance, modification of the steady-state creep law when low deviatoric stresses are considered (Charpentier et al., 1999 [74]; Wallner et al., 2000 [75]), the effect of moisture content in gas caverns (Horseman, 1988 [76]; Hunsche and Schulze, 1996 [77]), fracture mechanics and healing (Munson et al., 1999 [78]).

There is a little doubt that we have not heard the last word about the mechanical behavior of salt.

## 5. CAVERN ABANDONMENT

### 5.1 Introduction

In the past several years, there has been concern about the thermohydromechanical behavior of deep underground salt caverns after they have been sealed and abandoned. Interest in the very long-term behavior of such abandoned caverns has increased due to concerns for environmental protection, on one hand, and to several new projects in which caverns are used for disposal of non-hazardous, industrial or even low-level nuclear wastes, on the other (Wassmann, 1983 [79]; Ghoreychi and Cosenza, 1993 [80]; Rolfs et al., 1996 [81]; Tomasko et al., 1997 [82]; Bérest et al., 1997a [83]; Brassow and Thoms, 2000 [84]; Dusseault et al., 2001 [85]). The SMRI has set this problem at the center of its research program (Ratigan, 2000) [86] and has supported the Etrez test described in this chapter.

In most cases, prior to abandonment, the cavern will be filled with brine. Then a special steel plug will be set at casing seat (Pfeifle et al., 2000) [87] and cement will be poured in the well, isolating a large “bubble” of fluid, the evolution of which is the main concern of the present text.

After the cavern is sealed and abandoned, the cavern brine pressure will build up, as proved by many “shut-in pressure tests” (see, for instance, Bérest et al., 1979 [88]; Van Sambeek, 1990 [47]; You et al., 1994 [89]; Fokker, 1995 [90]). Bérest et al. (2000a) [91] describe several case histories in which initial pressure build-up rates in a closed cavern range from 4 MPa per year to 10 MPa per year — still more in very deep caverns, as the rate is faster when the cavern is younger, deeper or smaller.

The final value of cavern brine pressure is of utmost importance from the perspective of environmental protection. In salt formations, the natural state of stress resulting from overburden weight is generally assumed to be isotropic; this geostatic pressure ( $P_{\text{g}}$ ) is  $P_{\text{g}} \text{ (MPa)} = 0.022 H \text{ (m)}$  at cavern depth ( $H$ ). Several authors (Wallner, 1988 [92]; Bérest and Brouard, 1995 [93]) think that, in many cases, brine pressure will eventually reach a figure larger than the geostatic pressure, leading to hydrofracturing. There is some risk that brine flows upward through fractures, to shallow water-bearing strata, leading to water pollution, cavern collapse and subsidence. The consequences will be more severe when the cavern contains wastes.

## 5.2 Factors Contributing to Pressure Build-Up

### 5.2.1 Cavern Compressibility

A brine-filled closed cavern is a stiff body: a small reduction in cavern volume or a small increase in brine volume yields to a significant brine pressure build-up, or  $dV/V = b dP_i$ , where a typical value of the cavern compressibility factor is  $b = 4 \cdot 10^{-4} \text{ MPa}^{-1}$ , although larger values can be encountered (Bérest et al., 1999) [3].

### 5.2.2 Cavern Creep

The role of cavern creep has been clearly identified — see, for instance, Wallner (1988) [92], Cauberg et al. (1986) [94], Van Sambeek (1990) [47], Bérest (1990) [95], Rolfs et al. (1996) [81], Ghoreychi and Cosenza (1993) [80], Wallner and Paar (1997) [96] and Wallner et al. (2000) [75].

As a salt mass creeps toward a cavern, leading to cavern shrinkage, the cavern brine is offered smaller room, and its pressure builds up in a sealed cavern. Typical rates at the beginning of the process are  $\dot{V}/V = -3 \cdot 10^{-4}$  per year ( $\dot{P}_i = 0.75 \text{ MPa per year}$ ) in a 1000-m deep cavern and  $\dot{V}/V = -3 \cdot 10^{-2}$  per year ( $\dot{P}_i = 7.5 \text{ MPa per year}$ ) in a 2000-m deep cavern. After some time, the process becomes slower as the cavern pressure becomes higher, ultimately stopping when the cavern pressure is equal to geostatic ( $P_i = P_{\text{g}}$ ), after several centuries (Wallner and Paar, 1997) [96].

This process can be computed easily when the constitutive behavior of the rock salt is known. However, it is suspected that standard constitutive law (inferred from laboratory creep tests performed under relatively high deviatoric stresses) underestimate the actual creep rates observed at the end of the process, when cavern pressure is high (Charpentier et al., 1999 [74]; Wallner et al., 2000) [75].

### 5.2.3 Final Equilibrium

It is expected that creep ends when the cavity pressure balances the overburden pressure ( $P_i = P_{\text{g}}$ ). In fact, as pointed out by Wallner (1988) [92] and Ehgartner and Linn (1994) [97], an exact balance is reached only at cavern mid-depth. Salt rock is heavier than brine and, in the final state, brine pressure at the cavern top will exceed the geostatic pressure by an amount that is larger when the cavern is taller. If the cavern is tall enough, the rock tensile strength will be exceeded, and fracturing becomes likely.

### 5.2.4 Brine Thermal Expansion

The natural temperature of rock increases with depth. Caverns are leached out using soft water pumped from shallow aquifers with low temperatures. The transit time of water in the cavern is

a few days or weeks long, which means that the temperature of the brine in the cavern at the end of the leaching phase is lower than the natural temperature of rock by several dozens of Celsius degrees. The same can be said for a storage cavern filled with brine before being abandoned.

The initial temperature gap between the cavern brine and the rock formation slowly resorbs with time when the cavern is kept idle. The warning process can be dozens of years long (shorter in a small cavern). The process is easy to compute: thermal conduction takes place into the rock mass, and the heat flux is directed toward the cavern, whose temperature is almost uniform, because cavern brine is the seat of convection patterns that stir up the fluid, as has been proven by field observations (Bérest et al., 2001c) [14].

Heated brine expands, leading to a pressure build-up in a closed cavern (Bérest et al., 1979 [88]; Ehgartner and Linn, 1994 [97]; Bérest et al., 1997b [98]; Wallner et al., 2000 [75]). Since the thermal expansion coefficient of brine is  $\alpha = 4.4 \cdot 10^{-4} \text{ }^\circ\text{C}^{-1}$ , a  $1^\circ\text{C}$  temperature increase leads to an (approximate) 1-MPa pressure build-up.

In an actual cavern, cavern creep and brine thermal expansion combine to produce a build-up in brine pressure (Bérest and Brouard, 1995) [93]. In most cases, temperature increase is the preeminent factor, although an exception can be found in very deep caverns (You et al., 1994) [89].

### **5.3 Factors Contributing to Pressure Release**

#### **5.3.1 Rock Salt Permeability**

Rock salt permeability is exceedingly small, as explained in Section 3.2.1. When long-term cavern behavior is considered, “slightly permeable” and “impermeable” formations must be distinguished.

#### **5.3.2 Slightly Permeable Salt Formations**

In some cases, the micro-permeability of salt allows the brine pressure in a closed cavern to be released. This statement is true when thermal expansion effects of brine have dissipated and when the rock permeability is relatively high ( $K = 10^{-20} - 10^{-19} \text{ m}^2$ ). Then an equilibrium state can be reached when brine outflow toward the rock mass exactly balances the cavern volume loss due to creep. An in-situ test performed at the Etrez site in France supports this view and is described below.

#### **5.3.3 Impermeable Salt Formations**

When salt-formation permeability is even smaller ( $K < 10^{-21} \text{ m}^2$ ), no significant pressure release is allowed by brine permeation. However, the pioneering work of Fokker (1995) [90] proved that a “secondary” permeability can be induced by high brine pressure in the cavern: tensile effective stresses at cavern wall provoke rock damage and a porosity/permeability increase.

Such a phenomenon must be distinguished from discrete fracture creation, which is the ultimate result of this damaging process. With regard to hydraulic fracturing in salt, see paragraph 3.2.2 (i). Fokker's view has been confirmed by later SMRI-supported tests performed on hollow spherical samples (Bérest et al., 2000b [68] and 2001a [99]).

Computations have proven that this permeability increase is probably large enough to allow significant brine outflow from the cavern (Ehgartner and Tidwell, 2000) [100]. An earlier in-situ test, performed at the Etzel site in Germany (Rokahr et al., 2000) [18], was re-interpreted within the light of this induced, or secondary, permeability notion (Hauck et al., 2001 [101]; see below).

Although still open to discussion, a stress-induced permeability increase can provide optimistic scenarios for the long-term behavior of a closed cavern in an impermeable salt formation: the rock mass self-adapts when high fluid pressures are involved to prevent fracturing. In-situ validations are still needed.

#### 5.4 The Etrez 53 Test

This in-situ test, performed in a cavern at the Gaz de France storage site in Etrez, has been supported by the SMRI (Bérest et al., 2001c) [14]. Ez53 is a relatively small cavern ( $V = 7500 \pm 500 \text{ m}^3$ ). It was leached out in Spring 1982. Temperature profiles performed in Winter 1996 proved, as expected, that thermal equilibrium was reached 14 years after solution mining was completed (at this point, cavern behavior is governed by cavern creep and brine permeation). The cavern is 50-m high and has an average depth of 950 m; at such depth, moderate creep rates are expected. Brouard (1998) [33] measured the cavern creep rate when the well was opened to atmosphere and found that relative volumetric loss rate was approximately  $\dot{V}/V = -3 \cdot 10^{-4} \text{ year}^{-1}$ . Quintanilha (1996) [102], taking into account cavern pressure variations from 1982 to 1996, proved that the cavern steady-state creep rate was reached at the end of this period.

Permeability of the Etrez salt formation was assessed through various in-situ tests. Standard fuel leak tests (FLT) performed on several wells (Brouard et al., 2001) [13] have proven that the rock salt permeability was relatively high ( $K = 8 \cdot 10^{-22} - 3 \cdot 10^{-21} \text{ m}^2$ ). These figures had been confirmed by a one-year SMRI-supported test by Durup (1994) [12].

The test objective was to prove that the combined effects of cavern creep and brine permeation through the rock mass cause the cavern brine pressure to reach equilibrium when the cavern volumetric convergence rate (due to salt creep) exactly balances the brine outflow from the cavern (due to rock mass permeability).

To prevent gross misinterpretation, the annular space was filled with a light liquid, and an interface displacement rate method was designed to detect any fluid loss through the cemented casing (Bérest et al., 2001c) [14]. This system was accurate enough to allow indirect measurement of Earth tidal effects on cavern volume.

The test basically consisted of a trial-and-error process. Different cavern pressures were tested successively. When the well-head pressure rate remained consistently negative or positive for a

sufficiently long period of time, it is readjusted to a smaller or higher value through fluid withdrawal or injection in hopes of triggering a change in sign for the well-head pressure rate.

Results of the 500-day test are displayed on Figure 15: the cavern pressure decreases when higher than  $P_i = 13.0 \pm 0.1$  MPa (permeation prevails over creep) and increases when smaller than this value (reep prevails over permeation). The equilibrium pressure is much smaller than the geostatic pressure, which is  $P_{\Psi} = 20.5$  MPa.

Whether these results can be extended to other caverns is an open question. It should be kept in mind that several conditions make Ez53 a good candidate for low-equilibrium pressure: it is a small cavern (permeation is more effective in a small cavern), and the Etrez salt formation is probably more permeable than many others (for a comparison between the permeabilities of Etrez and Tersanne salt, see Brouard et al., 2001 [13]).

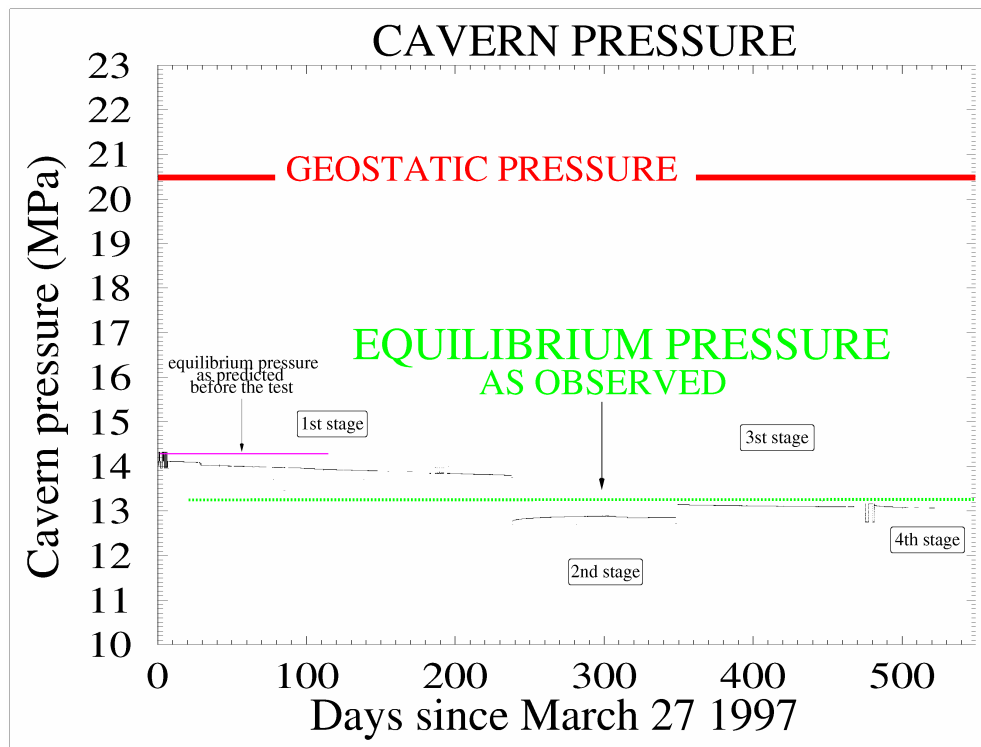

Figure 15 – The Etrez test (after Bérest et al., 2001c [14]). In this closed cavern brine pressure reaches an equilibrium value when brine volume loss due to permeation balances cavern volume loss due to creep.



## 5.5 The Etzel K102 Test

A complete description of this in-situ test, conducted by Consortium Druckaufbaustest K102, can be found in Rokahr et al. (2000) [18]. The K102 cavern is located at an oil-storage site in Etzel, Germany. It is a 233,000-m<sup>3</sup> cavern with a casing-shoe depth of 827.7 m. This 662-m high cavern (cavern roof depth = 850 m) was selected to “quantify the internal pressure in a brine filled cavern at the point of losing tightness” (Rokahr et al., 2000, p.90). Pressure was built up slowly from gradient  $1.2 \cdot 10^{-2}$  MPa/m to gradient  $2.2 \cdot 10^{-2}$  MPa/m and more (see Fig. 16); the geostatic gradient is believed to be in the range  $2.075 \pm 0.035 \cdot 10^{-2}$  MPa/m (slightly higher values were assumed before the test).

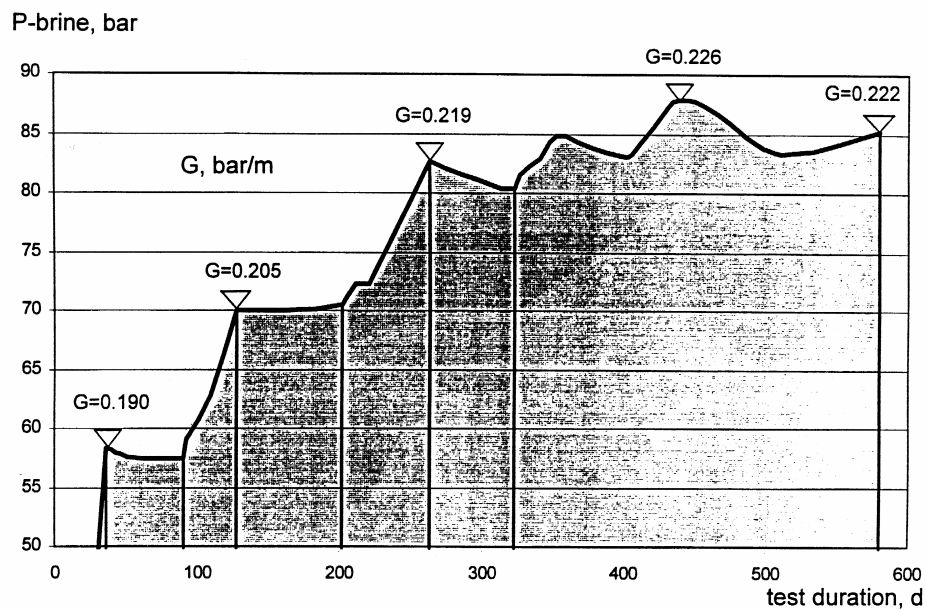

Figure 16 – The Etzel test (after Rokahr et al., 2000 [18]). Increasing pressure gradients are applied in the sealed cavern. When a 0.219 bar/m –gradient is reached, the apparent permeability of the cavern drastically increases.

During the first injection (up to a gradient of  $1.9 \cdot 10^{-2}$  MPa/m), the cavern compressibility factor was  $b = 4 \cdot 10^{-10} \text{ Pa}^{-1}$  — a standard figure (500 m<sup>3</sup> of brine were injected during this phase). The apparent compressibility of the cavern drastically increased during later injections.

- ? 134.4 m<sup>3</sup> were injected, to reach a gradient of  $2.05 \cdot 10^{-2}$  MPa/m.
- ? During the third step, 179.5 m<sup>3</sup> were injected to reach a gradient of  $2.19 \cdot 10^{-2}$  MPa/m, after which the pressure began to drop.

- ? After two months, extrapolation to a final gradient of  $2.17 \cdot 10^{-2}$  MPa/m was made. How thermal expansion and brine permeation (cavern creep is negligible in this context) combine to provide this asymptotic value is difficult to assess.
- ? During the fourth phase, injection resumed at a constant flow rate: a first pressure peak (gradient  $2.23 \cdot 10^{-2}$  MPa/m) was reached, followed by a negative pressure rate period. Two other pressure peaks were observed.

It is clear that increased brine permeation took place at least during the fourth injection phase. The results of the tests were explained by the onset of a secondary permeability (induced by brine pressure, when very near to rock stresses at the cavern wall). This assumption found some support in Fokker's laboratory test results (1995) [90]. Results of additional numerical computations are provided in Hauck et al. (2001) [101].

Somewhat similar observations had been made in closed caverns at the Vauvert site in France. After a fast pressure build-up, mainly governed by cavern creep (which is very effective in this 2000-m deep cavern), the pressure-versus-time curve reached a plateau (Bérest et al., 1979) [88]. No additional pressure build-up takes place, although thermal expansion is active. In this brine production site, however, caverns had been linked by hydrofracturing before leaching began, and the re-opening of preexisting fractures, rather than a more diffuse permeability increase, can be suspected.

## **6. CONCLUSION**

Underground storage safety entails many participants: operators, owners, consultants, regulatory authorities, unions, local public representatives and insurance companies — to name a few. The perspectives of these various participants do not coincide — they converge to a certain equilibrium point. Even in two contiguous states, the equilibrium point, as defined, for instance, by regulations, can differ widely. This equilibrium point moves slowly, at the pace of state-of-the-art advances; it moves more rapidly after an accident highlights a weakness of the safety system. The authors hope that their descriptions of several case studies is helpful in this respect.

## **ACKNOWLEDGMENTS**

The authors are indebted to many colleagues who provide them with fruitful comments. Joe Ratigan indicated several earlier misinterpretations of data. The authors take full responsibility for errors in the description of the accidents. Special Thanks to Gérard Durup and Kathy Sikora.

## REFERENCES

- [1] Thoms R.L., and Gehle R.M. A brief history of salt cavern use (keynote paper). Proc. 8<sup>th</sup> World Salt Symp., R.M. Geertman ed., Elsevier. Vol. I, 207-214, 2000.
- [2] Texas Railroad Commission, TAC Rules §3.95 and 3.97, available at <http://www.rrc.state.tx.us/>.
- [3] Bérest P., Bergues J., and Brouard B. Static and dynamic compressibility of deep underground caverns. Int. J. Rock Mech. & Mining Sci., 36 :1031–1049, 1999.
- [4] Furiga R.D., and Smith R.E. The Development of the Strategic Petroleum Reserve of the USA. Annales des Mines, 5-6, 47-62, 1983.
- [5] DOE (U.S. Department of Energy). OSC Strategic Petroleum West Hackberry Oil Storage Cavern Fire and Spill After Action Report, Vol. I., 1980.
- [6] Gebhardt F., Eby D., and Barnette D. Utilizing Coiled Tubing Technology to Control a Liquid Propane Storage Well Fire, A case history. Proc. SMRI Spring Meeting, Orlando, 301-308, 2001.
- [7] National Transportation Safety Board (NTSB). Highly Volatile Liquids Release from underground storage cavern and explosion, Mapco Natural Gas Liquids Inc., Brenham Texas, April 7, 1992. NTSB/PAR-93/01, PB93-916502.
- [8] Thiel W.R. Summary of SMRI Discussion Cavern Overfill Shut Down Triggers, Houston, Texas, April 16, 1996. SMRI Meeting, May 15, 1996 (available at SMRI).
- [9] Rokahr R., and Staudtmeister K. Rock Mechanical Study of the Load-Bearing Behaviour of a Gas Cavern in Rock Salt after a Blow Out. Proc. 7<sup>th</sup> Symp. on Salt, Kakihame H., Hardy H.R. Jr, Hoshi T., Toyokura K. eds, Elsevier, Vol I, 477-482, 1993.
- [10] Wallner M., and Eickemeier R. Subsidence and Fractures caused by Thermo-Mechanical Effects. Proc. SMRI Spring Meeting, Orlando, 363-371, 2001.
- [11] Dale T. and Hurtado L.D. WIPP air-intake shaft disturbed-rock zone study. Proc. 4<sup>th</sup> Conf. Mech. Beh. of Salt, Montreal, June 1996. Trans Tech Pub., Clausthal-Zellerfeld, Germany, 1997.
- [12] Durup J.G. Long term tests for tightness evaluations with brine and gas in salt. Proc. SMRI Fall Meeting, Hannover, 1994.
- [13] Brouard B., Bérest P., and Durup J.G. In-situ salt permeability testing. Proc. SMRI Fall Meeting, Albuquerque, 139-157, 2001.
- [14] Bérest P., Bergues J., Brouard B., Durup J.G., and Guerber B. A salt-cavern abandonment test. Int. J. Rock Mech. & Mining Sci., 2001c.

- [15] Brace W.F. Permeability of crystalline and argillaceous rocks. *Int. J. Rock Mech. & Mining Sci.*, 17: 241–251, 1980.
- [16] Schmidt Th. Fracture Tests for Determining Primary Stress Conditions in Salt Deposits Provide Clues to the Rock Mechanics of Salt Caverns. *Proc. 7<sup>th</sup> Symp. on Salt*, Kakihamé H., Hardy H.R. Jr, Hoshi T., Toyokura K. eds., Elsevier, Vol. I, 135-140, 1993.
- [17] Rummel F., Benke K., and Denzau H. Hydraulic fracturing stress measurements in the Krummhörn gas storage field, northwestern Germany. *Proc. SMRI Spring Meeting*, Houston, 1996.
- [18] Rokahr R.B., Hauck R., Staudtmeister K., and Zander-Schiebenhöfer D. The results of the pressure build-up test in the brine filled cavern Etzel K102. *Proc. SMRI Fall Meeting*, San Antonio, 89–103, 2000.
- [19] ATG. Manuel pour le transport et la distribution du gaz. Titre XIII, Stockages souterrains de gaz. Association technique de l'industrie du gaz en France, Paris, 1985.
- [20] Jordan, C.W. Cased Hole Logging for Determining Mechanical Integrity of Storage Wells. *Proc. SMRI Spring Meeting*, Tulsa, 1987.
- [21] Kelly, S.L. and Fleniken, J.A. The Development of Cement Evaluation Quality Control Measures for Cavern Wells. *Proc. SMRI Spring Meeting*, Las Vegas, 193-225, 1999.
- [22] Thoms R.L. and Kiddoo G. SMRI Technical Class, Guidelines for Safety Assessment of Salt Caverns, Roma, 113-140, 1998.
- [23] Johnson D.O. and Seni S.J. Regulation of Hydrocarbon Storage Operations in Texas. *Proc. SMRI Spring Meeting*, Orlando, 111-120, 2001.
- [24] Thiel W.R. Precision Methods for Testing the Integrity of Solution Mined Underground Storage Caverns,. *Proc. 7<sup>th</sup> Symp. on Salt*, Kakihamé H., Hardy H.R. Jr, Hoshi T., Toyokura K. eds, Vol. I, 377-384, 1993.
- [25] Bérest P., Brouard B., and Durup J.G. Tightness tests in salt-cavern wells. *Oil & Gas Science and Technology Journal - Rev. IFP*, Vol. 56, 5:451-469, 2001b.
- [26] Crotofino F. SMRI Reference for External Well Mechanical Integrity Testing/Performance, Data Evaluation and Assessment, 138 p., Report no. 95-0001 for the Solution Mining Research Institute, 1995.
- [27] Menzel W., and Schreiner W. Results of Rock Mechanical Investigations for Establishing Storage Cavern in Salt Formations. *Proc. 6<sup>th</sup> Symp on Salt*, B.C. Shreiber and H.L. Harner ed., Salt Institute, Vol I, 501-510, 1983.
- [28] Ratigan J. Ground Subsidence at Mount Belvieu, Texas (Panel Discussion - Surface Subsidence). *Proc. SMRI Spring Meeting*, Atlanta, 1991.

- [29] Durup J.G. Relationship between subsidence and cavern convergence at Tersanne (France). Proc. SMRI Spring Meeting, Atlanta, 1991.
- [30] Van Sambeek L.L. Evaluating Cavern Tests and Surface Subsidence Using Simple Numerical Models. Proc. 7<sup>th</sup> Symp. on Salt, Kakihane H., Hardy H.R. Jr, Hoshi T., Toyokura K. ed., Elsevier, Vol I, 433-439, 1993.
- [31] Nguyen Minh D., Maitourman H., Braham S., and Durup J.G. A Tentative Interpretation of Long-Term Surface Subsidence Measurements over a Solution Mined Cavern Field. Proc. 7<sup>th</sup> Symp. on Salt, Kakihane H., Hardy H.R. Jr, Hoshi T., Toyokura eds. Elsevier, Vol. I, 441-450, 1993.
- [32] Quintanilha de Menezes J.E., and Nguyen Minh D. Long term subsidence, prediction above storage cavity fields in salt layers. Proc. SMRI Fall Meeting, Cleveland, 249-273, 1996.
- [33] Brouard B. On the behavior of solution-mined caverns (in French). Thesis Dissertation, Ecole polytechnique, France, 1998.
- [34] Baar C.A. Applied salt-rock mechanics, 1. In Dlpments in Geot. Eng. 16-A, 143–147. Elsevier Science, Amsterdam, 1977.
- [35] Coates G.K., Lee C.A., McClain W.C., and Senseny P.E. Closure and Collapse of Man-Made Cavities. Proc. 6<sup>th</sup> Symp. on Salt, Shreiber B.C ed., The Salt Institute, Vol.II, 139-157, 1983.
- [36] Bérest P., Ghoreychi M., Fauveau M., and Lebitoux P. Mechanism of Creep in Gas storage caverns. Effects of gravity forces. Proc. 27<sup>th</sup> US Rock Mech. Symp., 1986.
- [37] Röhr H.U. Mechanical behavior of a gas storage cavern in evaporitic rocks. Proc. 4<sup>th</sup> Symp. on Salt, Vol II, 93-100, 1974.
- [38] Boucly Ph., and Legreneur J. Hydrocarbon Storage in Cavities leached out of Salt Formations. Proc. Int. Symp. Rock Store, M. Bergman ed., Pergamon, Vol. I, 251-257, 1980.
- [39] Boucly P. In situ experience and mathematical representation of the behavior of rock salt used in storage of gas. Proc. 1<sup>st</sup> Conf. Mech. Beh. of Salt, Pennsylvania, November 1981, 453–471. Trans Tech Pub., Clausthal-Zellerfeld, Germany, 453-471, 1984.
- [40] Fenix & Scisson, Inc. Eminence storage facility station 77 operating summary, November 1979 through April 1980. Unpublished report prepared for Transcontinental Gas Pipe Line Corporation, Report No. 4, p. 23.
- [41] Dreyer W. The Science of Rock Mechanics, 1. The Strength Properties of Rocks. Trans. Tech Pub., 501 pages, 1972.

- [42] Staupendahl G., and Schmidt M.W. Field Investigations in the Long-Term Deformational Behavior of a 10,000 m<sup>3</sup> Cavity at the Asse Salt Mine. Proc. 2<sup>nd</sup> Conf. Mech. Beh. of Salt, Hardy R.H. Jr and Langer M. eds, Trans Tech Pub, 511-526, 1984.
- [43] Quast P., and Schmidt M.W. Disposal of Medium- and Low-Level Radioactive Waste (MLW/LLW) in Leached Caverns. Proc. 6<sup>th</sup> Symp. On Salt, Schreiber B.C. and Harner H.L. eds., The Salt Institute, Vol. II, 217-234, 1983.
- [44] Denzau H. and Rudolph F. Field test for determining the convergence of a gas storage cavern under load conditions frequently changing between maximum and minimum pressure and its finite element modelling. Proc. SMRI Spring Meeting, Cracow, 71-84, 1997.
- [45] Brouard B. and Bérest P. A classification of salt according to their creep properties. Proc. SMRI Spring Meeting, New Orleans, 18-38, 1998.
- [46] Hardy H.R. Jr, Chabannes C.R., and Mrugola M. Laboratory and Theoretical Studies Relative to the Design of Salt Caverns for the Storage of Natural Gas. Proc. 6<sup>th</sup> Symp. on Salt, B.C. Shreiber and H.L. Harner ed., Salt Institute, Vol I, 385-416, 1983.
- [47] Van Sambeek LL. A simple method for modeling the pressure build up or flow of an abandoned solution well. Proc. SMRI Spring Meeting, Austin, 1990.
- [48] Vouille G., Tijani S.M., and de Grenier F. Experimental determination of the rheological behavior of Tersanne rock salt. Proc. 1<sup>st</sup> Conf. Mech. Beh. of Salt, Pennsylvania, November 1981. Trans Tech Pub., Clausthal-Zellerfeld, Germany, 407-420, 1984.
- [49] Hugout B. Mechanical behavior of salt cavities -in situ tests- model for calculating the cavity volume evolution. Proc. 2<sup>nd</sup> Conf. Mech. Beh. of Salt, Hannover, September 1984. Trans Tech Pub., Clausthal-Zellerfeld, Germany, 291-310, 1988.
- [50] Lux K.H. and Rokahr R.B. Some remarks on theoretical simulation models in salt cavern construction with regard to the evaluation of discharge measurements. Proc. Int. Symp. RockStore, M. Bergman ed., Pergamon, 329-335, 1980.
- [51] Schmidt U., and Staudtmeister K. Determining minimum permissible operating pressure for a gas cavern using the finite element method. Proc. Int. Conf. on Storage of Gases in Rock Caverns, B. Nilsen and J.Olsen ed., Balkema, 103-113, 1989.
- [52] Menzel W., and Schreiner W. Geomechanical aspects for the establishment and the operation of gas cavern stores in salt formations of the GDR. Proc. Int. Symp. Storage of Gases in Rock Caverns, B. Nilsen and J.Olsen ed., Balkema, 115-120, 1989.
- [53] Krieter M., Frohwein A., and Benke K. The impact of the Operating Mode of Gas Storage Caverns on Convergence Development. Proc. SMRI Spring Meeting, Cracow, 345-357, 1997.

- [54] Klafki, M., Bannach, A., and Achtzehn, L. Modeling and Control of Cavern Development for Underground Gas Storage Stassfurt, Germany. SMRI Spring Meeting, New Orleans, 154-173, 1998.
- [55] DeVries K.L., and Nieland J.D. Feasibility study for lowering the minimum gas pressure in solution-mined caverns based on geomechanical analyses of creep-induced damage and healing. Proc. SMRI Spring Meeting, Las Vegas, 153-182, 1999.
- [56] Thoms R.L., and Gehle R.M. Survey of existing caverns in US Salt Domes. Proc. 2<sup>nd</sup> Conf. Mech. Beh. of Salt, Hardy H.R. Jr and Langer M. eds., Trans Tech Pub, 703-716, 1988.
- [57] Hardy R.H. Jr and Langer M., editors. Proc. 1<sup>st</sup> Conf. Mech. Beh. of Salt, Pennsylvania, November 1981. Trans Tech Pub., Clausthal-Zellerfeld, Germany, 901 pages, 1984.
- [58] Hardy R.H. Jr and Langer M., editors. Proc. 2<sup>nd</sup> Conf. Mech. Beh. of Salt, Hannover, September 1984. Trans Tech Pub., Clausthal-Zellerfeld, Germany, 781 pages, 1988.
- [59] Hardy R.H. Jr, Langer M., Bérest P., and Ghoreychi M. eds. Proc. 3<sup>rd</sup> Conf. Mech. Beh. of Salt, Palaiseau, September 1993. Trans Tech Pub., Clausthal-Zellerfeld, Germany, 621 pages, 1996.
- [60] Aubertin M. and Hardy R.H., editors. Proc. 4<sup>th</sup> Conf. Mech. Beh. of Salt, Montreal, June 1996. Trans Tech Pub., Clausthal-Zellerfeld, Germany, 658 pages, 1997.
- [61] Cristescu N., and Hardy R.H. Jr. Proc 5<sup>th</sup> Conf. Mech. Beh. of Salt, Bucarest, August 1999, To be published in 2002.
- [62] Cristescu N. A general Constitutive Equation for Transient and Stationary creep of Rock Salt. Int. J. Rock Mech. Min. Sc. Geomech. Abst. 30, 125-140, 1993.
- [63] Cristescu N. and Hunsche U. A comprehensive constitutive equation for rock salt : determination and application. Proc. 3<sup>rd</sup> Conf. Mech. Beh. of Salt, Palaiseau, September 1993. Trans Tech Pub., Clausthal-Zellerfeld, Germany, 177–191, 1996.
- [64] Munson D.E. Constitutive Model of the Creep of Rock Salt Applied to Underground Room Closure. Int. J. Rock Mech. Min. Sc. Geomech. Abst. 34(2), 233-248, 1997.
- [65] Aubertin M., Sgaoula J., Servant S., Julien M.R., and Gill D.E., Landanyi B. An Up-to-Date Version of SUVIC-D for Modeling the Behavior of Salt. Proc. 4<sup>th</sup> Conf. Mech. Beh. Salt., Aubertin M. and Hardy R.H. Jr ed., Trans Tech Pub., 205-220, 1998.
- [66] Weidinger P., Blum W., Hampel A., and Hunsche U. Description of the Creep of Rock Salt with Composite Model – I. Transient Creep. Proc. 4<sup>th</sup> Conf. Mech. Beh. Salt, Aubertin M. and Hardy R.H. Jr ed., Trans Tech Pub., 277-285, 1998.

- [67] Hampel A., Hunsche U., Weidinger P., and Blum W. Description of the Creep of Rock Salt with The Composite Model. II Steady-State Creep. Proc. 4<sup>th</sup> Conf. Mech. Beh. Salt, Aubertin M. and Hardy R.H. Jr ed., Trans Tech Pub., 287-299, 1998.
- [68] Bérest P., Brouard B., and de Greef V. Salt permeability testing - the influence of permeability and stress on spherical hollow salt samples. Technical Report 2000-1, Solution Mining Research Institute (SMRI), 2000b.
- [69] Aubertin M., Gill D.E., Landanyi B., Modeling the Transient Inelastic Flow of Rocksalt. Proc. 7<sup>th</sup> Symp. Salt, Kakihana H., Hardy R.H. Jr, Hoshi T., Toyokura K. eds, Elsevier, Vol.I, 93-104, 1993.
- [70] Munson DE. Transient Analysis for the Multimechanism-Deformation Parameters of Several Domal Salts. Proc. SMRI Fall Meeting, Washington DC, 275-298, 1999.
- [71] Cosenza P. and Ghoreychi M. Coupling between mechanical behavior and transfer phenomena in salt. Proc. 3<sup>rd</sup> Conf. Mech. Beh. of Salt, Palaiseau, September 1993. Trans Tech Pub., Clausthal-Zellerfeld, Germany, 285–307, 1996.
- [72] Pfeifle T.W., DeVries K.L., and Nieland J.D. Damage – Induced Permeability Enhancement of Natural Rock Salt with Implications for Cavern Storage. Proc. SMRI Spring Meeting, New Orleans, 260-289, 1998.
- [73] Pfeifle T.W. and Hurtado L.H. Effect of Pore Pressure on Damage Accumulation in Salt. Proc. 8<sup>th</sup> World Salt Symp. R.M.Geertman ed., Elsevier, Vol.I, 307-312, 2000.
- [74] Charpentier J.P., Bérest P., and Blum P.A. Creep of a rock salt under small loading. Proc. SMRI Fall Meeting, Washington DC, 11–24, 1999.
- [75] Wallner M., Paar W.A., and Werner M. New results on cavern sealing and permeation processes. Proc. SMRI Fall Meeting, San Antonio, 127–135, 2000.
- [76] Horseman S.T. Moisture Content. A major uncertainty in Storage Cavity Closure Prediction. Proc. 2<sup>nd</sup> Conf. Mech. Beh. of Salt, Hannover, September 1984. Hardy H.R. Jr and Langer M. eds. Trans Tech Pub. 53-68, 1988.
- [77] Hunsche U. and Schulze O. Effects of humidity and Confining Pressure on Creep of Rock Salt. Proc. 3<sup>rd</sup> Conf. Mech. Beh. Salt. Hardy H.R., Langer M., Bérest P., Ghoreychi M. eds., Trans Tech.Pub., 237-248, 1996.
- [78] Munson D.E., Chan K.W., and Fossum A.F. Fracture and healing of rock salt related to salt caverns. Proc. SMRI Spring Meeting, Las Vegas, 67-90, 1999.
- [79] Wassmann Th. H. Cavity Utilization in the Netherlands. Proc. 6<sup>th</sup> Symp. Salt, Schreiber B.C. and Harner H.L. eds., The Salt Institute, Vol. II, 191-201, 1983.
- [80] Ghoreychi M. and Cosenza P. Quelques aspects de la sûreté à long terme des stockages dans le sel. Proc. 4<sup>ème</sup> Colloque Franco-Polonais, Nancy, 209–217, 1993.



- [81] Rolfs O., Schmidt U., and Crotogino F. Rock mechanical studies on the post-operational phase of a disposal cavern. Proc. 3<sup>rd</sup> Conf. Mech. Beh. of Salt, Clausthal-Zellerfeld, Germany, Trans Tech Pub., 417–26, 1996.
- [82] Tomasko D., Elcock D., Veil J., and Caudle D. Risk analyses for disposing of nonhazardous oil field wastes in salt caverns. Argonne National Laboratory, US Department of Energy, Contract W-31-109-ENG-38, 1997.
- [83] Bérest P., Brouard B., Beugin F., and Goldberg J. Storage of tritiated waters in salt caverns. Proc. SMRI Fall Meeting, El Paso, 49-63, 1997a.
- [84] Brassow C.L., and Thoms R.L. Use of solution-mined caverns for the disposal of hazardous and industrial waste products. Proc. 8<sup>th</sup> World Salt Symp., R.M. Geertman ed., Elsevier, Vol.I, 229-235, 2000.
- [85] Dusseault M.B., Bachu S., and Davidson B.C. Carbon dioxide sequestration potential in salt solution caverns in Alberta, Canada. Proc. SMRI Fall Meeting, Albuquerque, 77-96, 2001.
- [86] Ratigan J. A Status Report on the SMRI Cavern Sealing and Abandonment Program. Proc. SMRI Fall Meeting, San Antonio, 164-178, 2000.
- [87] Pfeifle T.W., Mellegard K.D., and Bruno M.S. Casing Sealing Study: Status Report. Solution Mining Research Institute research program (RFP-98-3). Proc. SMRI Fall Meeting, San Antonio, 139–163, 2000.
- [88] Bérest P., Ledoux E., Legait B., and de Marsily G. Effets thermiques dans les cavités en couches salifères. Proc. 4<sup>ème</sup> congrès I.S.M.R., Montreux, Septembre 1979, Vol. I, 31–35. Balkema, Rotterdam, 1979.
- [89] You Th., Maisons Ch., and Valette M. Experimental procedures for the closure of the brine production caverns of the “Saline de Vauvert” site. Proc. SMRI Fall Meeting, Hannover, 1994.
- [90] Fokker P.A. The Behavior of Salt and Salt caverns. Thesis Dissertation, Delft University of Technology, Pays-Bas, 1995.
- [91] Bérest P., Brouard B., and Durup G. Shut-In Pressure Tests – Case Studies. Proc. SMRI Fall Meeting, San Antonio, 105-126, 2000a.
- [92] Wallner M. Frac-pressure risk for cavities in rock salt. Proc. 2<sup>nd</sup> Conf. Mech. Beh. Of Salt, Hannover, September 1984, 645–658. Trans Tech Pub., Clausthal-Zellerfeld, Germany, 1988.
- [93] Bérest P. and Brouard B. Behavior of sealed solution-mined caverns. Proc. SMRI Spring Meeting, New Orleans, 1995.

- [94] Cauberg H., Kuilman B., Valkering B., and Walters J.V. Rock mechanical behavior and sealing aspects of a closed-in salt cavity filled with brine. Proc. SMRI Fall Meeting, Amsterdam, 1986.
- [95] Bérest P. Les problèmes soulevés par l'abandon des cavités de dissolution profondes dans le sel gemme. In Stockage en souterrain, 115–130. Presses des Ponts et Chaussées, 1990.
- [96] Wallner M., and Paar W.A. Risks of progressive pressure build up in a sealed cavern. Proc. SMRI Fall Meeting, El Paso, 177-188, 1997.
- [97] Ehgartner B.L. and Linn J.K. Mechanical behavior of sealed SPR caverns. Proc. SMRI Spring Meeting, Houston, 1994.
- [98] Bérest P., Brouard B., and Durup J.G. Behavior of sealed solution-mined caverns. Proc. 4<sup>th</sup> Conf. Mech. Beh. of Salt, Montreal, June 1996, 511–524. Trans Tech Pub., Clausthal-Zellerfeld, Germany, 1997b.
- [99] Bérest P., Brouard B., and de Greef V. Salt permeability testing. Technical Report RFP 98-1 – Part 2, Laboratoire de Mécanique des Solides, Ecole polytechnique. Report for the Solution Mining Research Institute, 2001a.
- [100] Ehgartner B. and Tidwell V. Multiphase flow and cavern abandonment. Proc. SMRI Fall Meeting, San Antonio, 73–86, 2000.
- [101] Hauck R., Staudtmeister K., and Zander-Schiebenhöfer D. The results of the Numerical Simulation of the Etzel Test. Proc. SMRI Spring Meeting, Orlando, 213-226, 2001
- [102] Quintanilha de Menezes J.E., Méthodes analytiques et numériques pour l'étude des cavités salines profondes. Thesis Dissertation, Ecole polytechnique, Palaiseau, France, December 1996.